



重泰减速机

ZHONG TAI REDUCER

品质铸就品牌

F系列平行轴齿斜轮减速机

地址：江苏省梁溪区蔚蓝路97号

24小时服务热线：400-710-9918

技术服务热线：13861467735



扫一扫加微信



型号与标记:

Type Designations:

<p style="text-align: center;">F F 37-Y 0.55-4P-23.88-M1- 270°</p> <p>减速机类型 ————</p> <p>结构形式 ————</p> <p>规格 ————</p> <p>电机代号 ————</p> <p>电机功率、极数 ————</p> <p>传动比 ————</p> <p>安装形式 ————</p> <p>电机接线盒位置 ————</p>	<p style="text-align: center;">F F 37-Y 0.55-4P-23.88-M1- 270°</p> <p>Gear units type ————</p> <p>Structure ————</p> <p>Size ————</p> <p>Motor code ————</p> <p>Motor power, pole ————</p> <p>Ratio ————</p> <p>Mounting position ————</p> <p>Position of the motor thermal box ————</p>																																								
<p>减速机类型: 平行轴斜齿轮减速机</p>	<p>Gear units type: Parallel shaft helical gear units</p>																																								
<p>结构形式:</p> <table border="0"> <tr><td>普通轴伸式 (省略)</td><td></td></tr> <tr><td>轴装式</td><td>A</td></tr> <tr><td>轴伸法兰式</td><td>F</td></tr> <tr><td>轴装法兰式</td><td>AF</td></tr> <tr><td>轴装小法兰式</td><td>AZ</td></tr> <tr><td>普通轴伸式, 轴输入</td><td>S</td></tr> <tr><td>普通轴装式, 轴输入</td><td>AS</td></tr> <tr><td>轴伸法兰式, 轴输入</td><td>FS</td></tr> <tr><td>轴装法兰式, 轴输入</td><td>AFS</td></tr> </table>	普通轴伸式 (省略)		轴装式	A	轴伸法兰式	F	轴装法兰式	AF	轴装小法兰式	AZ	普通轴伸式, 轴输入	S	普通轴装式, 轴输入	AS	轴伸法兰式, 轴输入	FS	轴装法兰式, 轴输入	AFS	<p>Structure:</p> <table border="0"> <tr><td>Foot-mounted solid shaft output</td><td>(-)</td></tr> <tr><td>Hollow shaft output</td><td>A</td></tr> <tr><td>Flange-mounted solid shaft output</td><td>F</td></tr> <tr><td>Flange-mounted hollow shaft output</td><td>AF</td></tr> <tr><td>Short-flange-mounted hollow shaft output</td><td>AZ</td></tr> <tr><td>Foot-mounted solid shaft output, shaft input</td><td>S</td></tr> <tr><td>Hollow shaft output, shaft input</td><td>AS</td></tr> <tr><td>Flange-mounted solid shaft output, shaft input</td><td>FS</td></tr> <tr><td>Flange-mounted hollow shaft output, shaft input</td><td>AFS</td></tr> </table>	Foot-mounted solid shaft output	(-)	Hollow shaft output	A	Flange-mounted solid shaft output	F	Flange-mounted hollow shaft output	AF	Short-flange-mounted hollow shaft output	AZ	Foot-mounted solid shaft output, shaft input	S	Hollow shaft output, shaft input	AS	Flange-mounted solid shaft output, shaft input	FS	Flange-mounted hollow shaft output, shaft input	AFS				
普通轴伸式 (省略)																																									
轴装式	A																																								
轴伸法兰式	F																																								
轴装法兰式	AF																																								
轴装小法兰式	AZ																																								
普通轴伸式, 轴输入	S																																								
普通轴装式, 轴输入	AS																																								
轴伸法兰式, 轴输入	FS																																								
轴装法兰式, 轴输入	AFS																																								
Foot-mounted solid shaft output	(-)																																								
Hollow shaft output	A																																								
Flange-mounted solid shaft output	F																																								
Flange-mounted hollow shaft output	AF																																								
Short-flange-mounted hollow shaft output	AZ																																								
Foot-mounted solid shaft output, shaft input	S																																								
Hollow shaft output, shaft input	AS																																								
Flange-mounted solid shaft output, shaft input	FS																																								
Flange-mounted hollow shaft output, shaft input	AFS																																								
<p>规格: (见选型参数表)</p>	<p>Size: (see selection table)</p>																																								
<p>电机代号:</p> <table border="0"> <tr><td>普通 (更新)</td><td>Y(Y2)</td></tr> <tr><td>防 爆</td><td>B</td></tr> <tr><td>直 流</td><td>Z</td></tr> <tr><td>制 动</td><td>YEJ</td></tr> <tr><td>多 速</td><td>D</td></tr> <tr><td>变 频</td><td>YVP</td></tr> <tr><td>电磁调速</td><td>YCT</td></tr> <tr><td>冶金起重</td><td>R</td></tr> <tr><td>变频制动</td><td>YVPJ</td></tr> <tr><td>辊 道</td><td>G</td></tr> </table>	普通 (更新)	Y(Y2)	防 爆	B	直 流	Z	制 动	YEJ	多 速	D	变 频	YVP	电磁调速	YCT	冶金起重	R	变频制动	YVPJ	辊 道	G	<p>Motor code:</p> <table border="0"> <tr><td>Ordinary(renew)</td><td>Y(Y2)</td></tr> <tr><td>Flame-proof</td><td>B</td></tr> <tr><td>Direct current</td><td>Z</td></tr> <tr><td>Brake</td><td>YEJ</td></tr> <tr><td>Multi-speed</td><td>D</td></tr> <tr><td>Variable frequency</td><td>YVP</td></tr> <tr><td>Electromagnetism speed modulation</td><td>YCT</td></tr> <tr><td>Hoisting in metallurgy</td><td>R</td></tr> <tr><td>Variable frequency and brake</td><td>YVPJ</td></tr> <tr><td>Roller tables</td><td>G</td></tr> </table>	Ordinary(renew)	Y(Y2)	Flame-proof	B	Direct current	Z	Brake	YEJ	Multi-speed	D	Variable frequency	YVP	Electromagnetism speed modulation	YCT	Hoisting in metallurgy	R	Variable frequency and brake	YVPJ	Roller tables	G
普通 (更新)	Y(Y2)																																								
防 爆	B																																								
直 流	Z																																								
制 动	YEJ																																								
多 速	D																																								
变 频	YVP																																								
电磁调速	YCT																																								
冶金起重	R																																								
变频制动	YVPJ																																								
辊 道	G																																								
Ordinary(renew)	Y(Y2)																																								
Flame-proof	B																																								
Direct current	Z																																								
Brake	YEJ																																								
Multi-speed	D																																								
Variable frequency	YVP																																								
Electromagnetism speed modulation	YCT																																								
Hoisting in metallurgy	R																																								
Variable frequency and brake	YVPJ																																								
Roller tables	G																																								
<p>电机功率、极数: (见选型参数表)</p>	<p>Motor power, pole : (see selection table)</p>																																								
<p>传动比: (见选型参数表)</p>	<p>Ratio: (see selection table)</p>																																								
<p>安装形式: M1、M2、M3、M4、M5、M6 (见第129页)</p>	<p>Mounting position: M1、M2、M3、M4、M5、M6(see page 129)</p>																																								
<p>电机接线盒位置: 0°、90°、180°、270° (见第129页)</p>	<p>Position of the motor thermal box: 0°、90°、180°、270° (see page 129)</p>																																								

F

安装形式:
Mounting position:

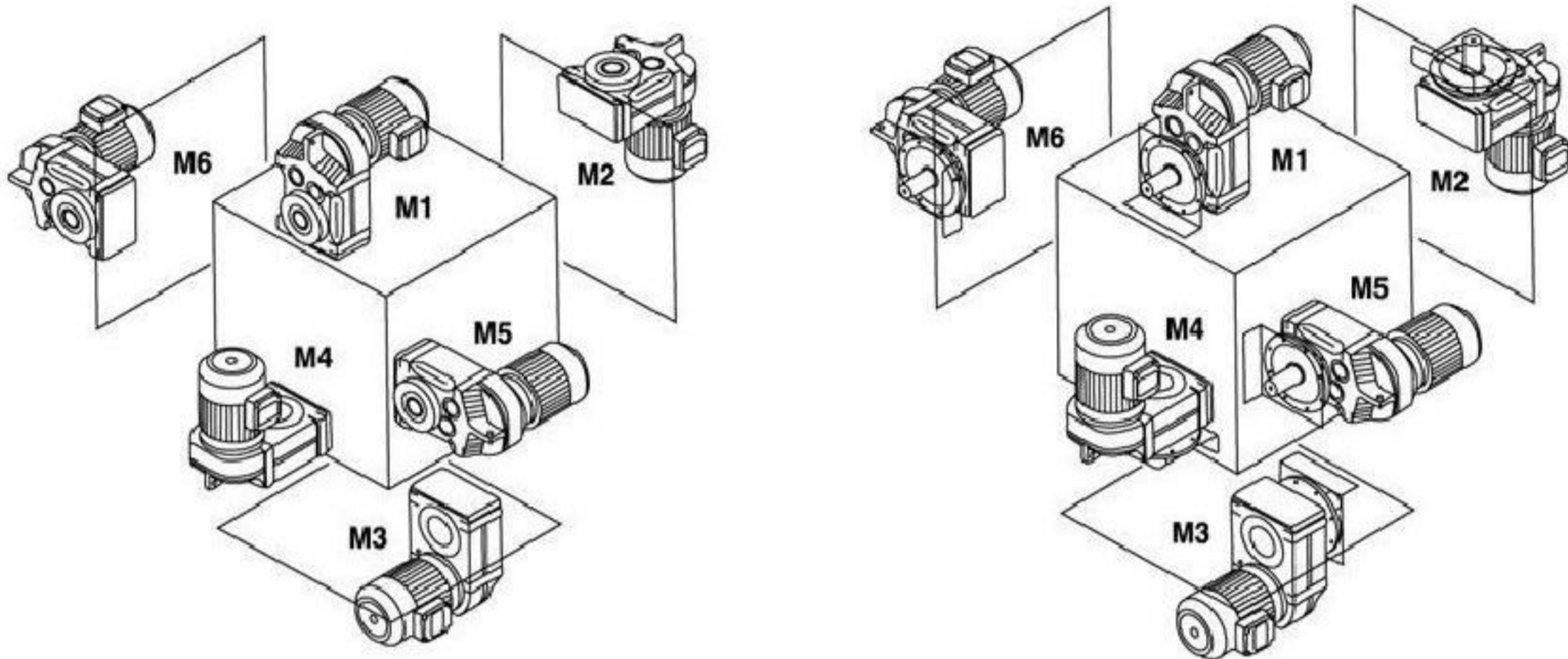

电机接线盒位置:
Position of the motor thermal box

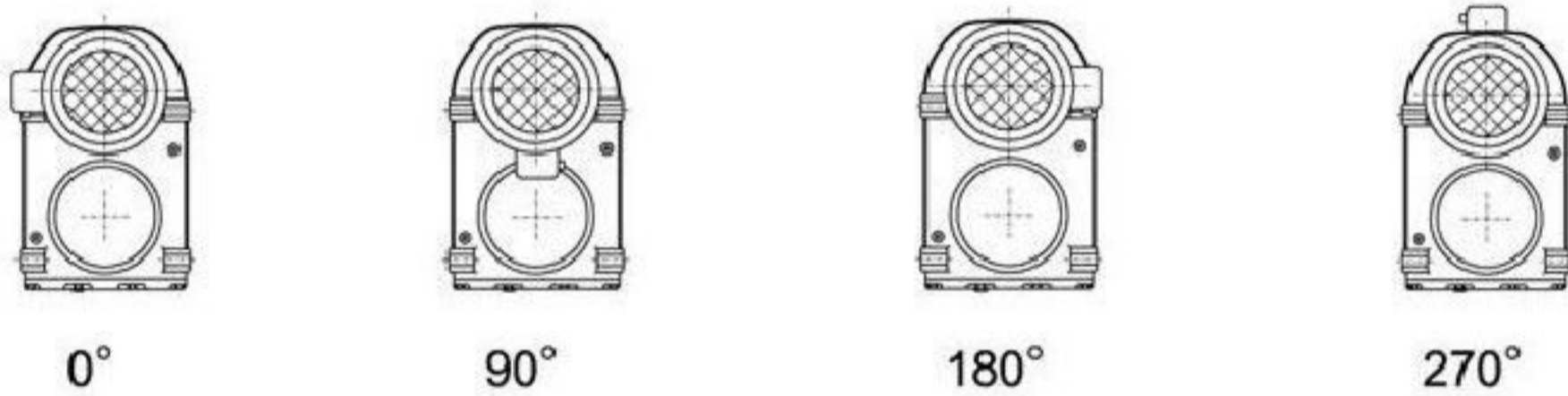

F

输入功率及许用转矩
Input power rating and permissible torque

规格 Size	37	47	57	67	77	87	97	107	127	157
结构形式 Structure	F FA FF FAF FAZ									
输入功率 Input power rating(kW)	0.18~3	0.18~3	0.18~5.5	0.18~5.5	0.37~11	0.75~22	1.1~30	2.2~45	7.5~90	11~200
传动比 Ratio	3.81~128.51	5.06~189.39	5.18~199.70	4.21~228.99	4.30~281.71	4.12~270.68	4.68~280.76	6.20~254.40	4.63~172.17	11.92~267.43
许用转矩(N.m) Permissible torque	200	400	600	820	1500	3000	4300	7840	12000	18000

减速机重量
Gear unit weight

规格 Size	37	47	57	67	77	87	97	107	127	157
重量(kg) Weight	13	18	34	55	90	150	260	402	700	950

所注重量为平均值,仅供参考
The weights are mean values, only for reference.

润滑油量表
Lubrication table

F...:

规格 Size	润滑油量 (升)			Fill quantity in liters		
	M1	M2	M3	M4	M5	M6
F37	1	1.2	0.7	1.2	1	1.1
F47	1.5	1.8	1.1	1.9	1.5	1.7
F57	2.6	3.7	2.1	3.5	2.8	2.9
F67	2.7	3.8	1.9	3.8	2.9	3.2
F77	5	7.3	4.3	8	6	6.3
F87	10	13.0	7.7	13.8	10.8	11
F97	18.5	22.5	12.6	25.2	18.5	20
F107	24.5	32	19.5	37.5	27	27
F127	40.5	55	34	61	46.5	47
F157	69	104	63	105	86	78

FF...:

规格 Size	润滑油量 (升)			Fill quantity in liters		
	M1	M2	M3	M4	M5	M6
FF37	1	1.2	0.7	1.3	1	1.1
FF47	1.6	1.9	1.1	1.9	1.5	1.7
FF57	2.8	3.8	2.1	3.7	2.9	3
FF67	2.7	3.8	1.9	3.8	2.9	3.2
FF77	5.1	7.3	4.3	8.1	6	6.3
FF87	10.3	13.2	7.8	14.1	11	11.2
FF97	19	22.5	12.6	25.5	18.9	20.5
FF107	25.5	32	19.5	38.5	27.5	28
FF127	41.5	56	34	63	46.5	49
FF157	72	105	64	106	87	79

FA...、FAF...、FAZ...:

规格 Size	润滑油量 (升)			Fill quantity in liters		
	M1	M2	M3	M4	M5	M6
F..37	1	1.2	0.7	1.2	1	1.1
F..47	1.5	1.8	1.1	1.9	1.5	1.7
F..57	2.7	3.8	2.1	3.6	2.9	3
F..67	2.7	3.8	1.9	3.8	2.9	3.2
F..77	5	7.3	4.3	8	6	6.3
F..87	10	13.0	7.7	13.8	10.8	11
F..97	18.5	22.5	12.6	25.0	18.5	20
F..107	24.5	32	19.5	37.5	27	27
F..127	39	55	34	61	45	46.5
F..157	68	103	62	104	85	77



重泰减速机

ZHONG TAI REDUCER

品质铸就品牌

输出转速 Output speed r/min	输出扭矩 Output torque Nm	传动比 Ratio i	使用系数 Service factor f _B	机型号 Type Type	极数 Pole p	输出转速 Output speed r/min	输出扭矩 Output torque Nm	传动比 Ratio i	使用系数 Service factor f _B	机型号 Type Type	极数 Pole p
0.18kW						0.18kW					
0.11	14324	13014	0.79			2.5	616	560	0.92		
0.12	12930	11748	0.87	FA 127R77	4	2.7	558	507	1.01		
0.14	11305	10271	1.00	FAF127R77	4	3.1	499	453	1.13		
0.16	9797	8901	1.15	F 127R77	4	3.3	469	426	1.20	FA 57R37	4
0.18	8478	7703	1.33	FF 127R77	4	3.6	426	387	1.32	FAF57R37	4
0.21	7449	6768	1.51			4.2	363	330	1.55	F 57R37	4
						4.7	328	298	1.72	FF 57R37	4
0.16	9408	8548	0.78			5.3	288	262	1.96		
0.18	8448	7675	0.87			6.2	249	226	2.3		
0.21	7281	6615	1.01			7.0	220	200	2.6		
0.24	6406	5820	1.15	FA 107R77	4	4.1	371	337	1.01		
0.27	5749	5223	1.28	FAF107R77	4	4.6	331	301	1.13		
0.30	5027	4567	1.47	F 107R77	4	4.7	322	293	1.17		
0.39	3875	3521	1.90	FF 107R77	4	4.9	314	285	1.20	FA 47R17	4
0.46	3343	3037	2.2			6.0	253	230	1.49	FAF47R17	4
0.50	3033	2756	2.4			6.1	250	227	1.50	F 47R17	4
0.59	2607	2369	2.8			6.4	238	216	1.58	FF 47R17	4
0.67	2276	2068	3.2			7.4	207	188	1.82		
						7.9	194	176	1.94		
0.32	4815	4375	0.84			8.2	187	170	1.00	FA 37R17	4
0.35	4343	3946	0.9			8.3	185	168	1.02	FAF37R17	4
0.41	3743	3401	1.1			10	146	133	1.28	F 37R17	4
0.47	3246	2949	1.2	FA 97R57	4	11	142	129	1.32	FF 37R17	4
0.54	2851	2590	1.4	FAF97R57	4						
0.61	2495	2267	1.6	F 97R57	4						
0.70	2189	1989	1.8	FF 97R57	4						
0.80	1914	1739	2.1								
0.90	1697	1542	2.4								
1.0	1475	1340	2.7			3.0	536	281.71	2.6	FA 77	6
1.2	1301	1182	3.1			3.2	500	262.93	2.8	FAF77	6
						3.8	429	225.79	3.3	F 77	6
										FF 77	6
0.48	3171	2881	0.9							FA 67	6
0.54	2834	2575	1.0			3.7	435	228.99	1.77	FAF67	6
0.63	2420	2199	1.2			4.4	371	195.39	2.1	F 67	6
0.72	2124	1930	1.3	FA 87R57	4	5.0	325	170.85	2.4	FF 67	6
0.81	1881	1709	1.5	FAF87R57	4						
0.93	1643	1493	1.7	F 87R57	4						
1.1	1431	1300	2.0	FF 87R57	4	6.1	266	228.99	2.9	FA 67	4
1.2	1264	1148	2.2			7.1	227	195.39	3.4	FAF67	4
1.4	1112	1010	2.5			8.1	199	170.85	3.9	F 67	4
1.6	976	887	2.9							FF 67	4
1.8	859	780	3.3								
						4.3	380	199.70	1.49		
0.8	1902	1728	0.7			4.6	349	183.60	1.62	FA 57	6
0.9	1698	1543	0.8			5.4	299	157.09	1.89	FAF57	6
1.0	1490	1354	0.9			6.2	259	136.16	2.2	F 57	6
1.2	1316	1196	1.1	FA 77R37	4	6.7	242	127.27	2.3	FF 57	6
1.3	1156	1050	1.2	FAF77R37	4	7.7	209	110.01	2.7		
1.5	998	907	1.4	F 77R37	4						
1.7	892	810	1.6	FF 77R37	4						
2.0	781	710	1.8			7.0	232	199.70	2.4		
2.3	660	600	2.1			7.6	213	183.60	2.6	FA 57	4
						8.8	183	157.09	3.1	FAF57	4
1.6	944	858	0.82			10	158	136.16	3.6	F 57	4
1.9	812	738	0.95			11	148	127.27	3.8	FF 57	4
2.2	689	626	1.12								
2.4	630	572	1.22			4.5	360	189.39	1.0		
2.8	550	500	1.40			4.9	331	174.13	1.1	FA 47	6
2.8	547	497	1.41			5.7	283	148.98	1.3	FAF47	6
3.1	500	454	1.54	FA 67R37	4	6.6	245	129.14	1.5	F 47	6
3.3	470	427	1.64	FAF67R37	4	7.0	229	120.70	2.5	FF 47	6
3.5	431	392	1.79	F 67R37	4						
3.8	403	366	1.91	FF 67R37	4	7.3	220	189.39	1.71	FA 47	4
4.2	367	333	2.1			8.0	202	174.13	1.86	FAF47	4
4.7	327	297	2.4			9.3	173	148.98	2.2	F 47	4
5.3	287	261	2.7			11	150	129.14	2.5	FF 47	4
5.8	262	238	2.9			12	140	120.70	2.7		
7.0	220	200	3.5								

F



重泰减速机

ZHONG TAI REDUCER

品质铸就品牌

F

输出转速 Output speed r/min	输出扭矩 Output torque Nm	传动比 Ratio i	使用系数 Service factor f _s	机型号 Type Type	极数 Pole p	输出转速 Output speed r/min	输出扭矩 Output torque Nm	传动比 Ratio i	使用系数 Service factor f _s	机型号 Type Type	极数 Pole p
0.18kW						0.25kW					
7.2	224	117.88	0.84			0.72	2950	1930	1.0		
8.5	191	100.36	0.99	FA 37	6	0.81	2613	1709	1.1		
9.8	164	86.53	1.14	FAF37	6	0.93	2282	1493	1.2	FA 87R57	4
11	153	80.65	1.23	F 37	6	1.1	1987	1300	1.4	FAF87R57	4
12	134	70.50	1.40	FF 37	6	1.2	1755	1148	1.6	F 87R57	4
11	149	128.51	1.26			1.4	1544	1010	1.8	FF 87R57	4
12	137	117.88	1.37			1.6	1356	887	2.1		
14	117	100.36	1.61			1.8	1192	780	2.4		
16	101	86.53	1.87			2.1	1030	674	2.7		
17	94	80.65	2.0			1.3	1605	1050	0.88		
20	82	70.50	2.3			1.5	1387	907	1.02		
21	77	66.09	2.4			1.7	1238	810	1.14	FA 77R37	4
24	68	58.32	2.8			2.0	1085	710	1.30	FAF77R37	4
25	63	54.54	3.0			2.3	917	600	1.54	F 77R37	4
27	60	51.70	3.1			2.6	803	525	1.76	FF 77R37	4
30	55	47.02	3.4			3.0	717	469	1.97		
32	51	43.83	3.7			3.4	630	412	2.2		
36	45	38.31	4.2			2.2	980	641	0.79		
39	42	35.91	4.5	FA 37	4	2.4	874	572	0.88		
44	37	31.69	5.1	FAF37	4	2.7	778	509	0.99		
49	33	28.09	5.8	F 37	4	2.8	764	500	1.01	FA 67R37	4
58	28	23.88	6.8	FF 37	4	3.1	694	454	1.11	FAF67R37	4
59	27	23.63	6.8			3.2	668	437	1.15	F 67R37	4
68	24	20.57	7.9			3.5	599	392	1.29	FF 67R37	4
72	22	19.27	8.4			4.2	509	333	1.51		
82	20	17.03	9.5			4.7	454	297	1.70		
88	18	15.81	10.2			5.3	399	261	1.93		
97	17	14.33	11			5.8	364	238	2.1		
108	15	12.87	13			3.6	592	387	0.95		
125	13	11.08	14			4.2	504	330	0.97		
133	12	10.42	14			5.6	381	249	1.11		
155	10	8.97	16			3.6	584	382	1.12	FA 57R37	4
185	8.7	7.51	16			4.2	505	330	1.21	FAF57R37	4
204	7.9	6.81	17			4.7	456	298	1.24	F 57R37	4
227	7.1	6.11	18			5.3	401	262	1.48	FF 57R37	4
264	6.1	5.27	19			6.2	345	226	1.63		
281	5.8	4.95	20			7.0	306	200	1.84		
326	5.0	4.26	21			8.4	254	166	2.2		
0.25kW						0.25kW					
0.16	13607	8901	0.83			6.0	352	230	1.07		
0.18	11775	7703	0.96	FA 127R77	4	6.1	347	227	1.08		
0.21	10346	6768	1.09	FAF127R77	4	6.4	330	216	1.14		
0.23	9131	5973	1.24	F 127R77	4	7.2	294	192	1.28	FA 47R17	4
0.27	7760	5076	1.45	FF 127R77	4	7.4	287	188	1.31	FAF47R17	4
0.31	6827	4466	1.7			7.9	269	176	1.40	F 47R17	4
0.24	8897	5820	0.83			8.0	264	173	1.42	FF 47R17	4
0.27	7984	5223	0.92			9.4	226	148	1.66		
0.30	6982	4567	1.06			11	199	130	1.89		
0.40	5262	3442	1.40	FA 107R77	4	10	203	133	0.92	FA 37R17	4
0.46	4643	3037	1.59	FAF107R77	4	11	197	129	0.95	FAF37R17	4
0.50	4213	2756	1.75	F 107R77	4	12	180	118	1.04	F 37R17	4
0.59	3621	2369	2.0	FF 107R77	4	14	150	98	1.25	FF 37R17	4
0.67	3161	2068	2.3			16	133	87	1.41		
0.87	2441	1597	3.0			3.0	744	281.71	1.9	FA 77	6
0.99	2142	1401	3.4			3.2	694	262.93	2.0	FAF77	6
0.47	4508	2949	0.90			3.8	596	225.79	2.4	F 77	6
0.54	3959	2590	1.02			4.3	524	198.31	2.7	FF 77	6
0.61	3466	2267	1.17	FA 97R57	4	4.5	497	188.40	2.8		
0.63	3362	2199	1.20	FAF97R57	4						
0.80	2658	1739	1.52	F 97R57	4						
0.90	2357	1542	1.71	FF 97R57	4						
1.0	2032	1329	2.0								
1.2	1807	1182	2.2								
1.3	1578	1032	2.6								



重泰减速机

ZHONG TAI REDUCER

品质铸就品牌

输出转速 Output speed r/min	输出扭矩 Output torque Nm	传动比 Ratio i	使用系数 Service factor f _B	机型号 Type Type	极数 Pole p	输出转速 Output speed r/min	输出扭矩 Output torque Nm	传动比 Ratio i	使用系数 Service factor f _B	机型号 Type Type	极数 Pole p
0.25kW						0.25kW					
3.7	605	228.99	1.3			204	11	6.81	12		
4.4	516	195.39	1.5	FA 67	6	227	10	6.11	13	FA 37	4
5.0	451	170.85	1.7	FAF67	6	264	8.5	5.27	14	FAF37	4
5.2	429	162.31	1.8	F 67	6	281	8.0	4.95	14	F 37	4
6.0	376	142.40	2.1	FF 67	6	326	6.9	4.26	15	FF 37	4
0.37kW						0.37kW					
6.1	370	228.99	2.1	FA 67	4	0.21	15312	6768	0.74		
7.1	315	195.39	2.4	FAF67	4	0.23	13514	5973	0.83	FA 127R77	4
8.1	276	170.85	2.8	F 67	4	0.27	11484	5076	0.98	FAF127R77	4
8.6	262	162.31	2.9	FF 67	4	0.31	10104	4466	1.12	F 127R77	4
9.8	230	142.40	3.4			0.36	8751	3868	1.29	FF 127R77	4
4.3	527	199.70	1.07			0.41	7699	3403	1.47		
4.6	485	183.60	1.16	FA 57	6	0.47	6758	2987	1.67		
5.4	415	157.09	1.4	FAF57	6	0.46	6871	3037	1.07	FA 107R77	4
6.2	360	136.16	1.6	F 57	6	0.50	6235	2756	1.16	FAF107R77	4
6.7	336	127.27	1.7	FF 57	6	0.59	5360	2369	1.35	F 107R77	4
7.7	290	110.01	1.9			0.67	4679	2068	1.54	FF 107R77	4
7.0	322	199.70	1.7			0.87	3613	1597	2.0		
7.6	296	183.60	1.9	FA 57	4	0.61	5129	2267	0.79		
8.8	254	157.09	2.2	FAF57	4	0.70	4505	1991	0.90		
10	220	136.16	2.6	F 57	4	0.80	3934	1739	1.03	FA 97R57	4
11	205	127.27	2.7	FF 57	4	0.90	3489	1542	1.16	FAF97R57	4
13	178	110.01	3.2			1.0	3032	1340	1.3	F 97R57	4
5.7	393	148.98	1.0	FA 47	6	1.2	2674	1182	1.5	FF 97R57	4
6.6	341	129.14	1.1	FAF47	6	1.3	2335	1032	1.7		
7.0	319	120.70	1.2	F 47	6	1.5	2052	907	2.0		
8.1	275	104.33	1.4	FF 47	6	1.1	2941	1300	1.0		
7.3	306	189.39	1.2			1.2	2597	1148	1.1		
8.0	281	174.13	1.3	FA 47	4	1.4	2285	1010	1.2	FA 87R57	4
9.3	241	148.98	1.6	FAF47	4	1.6	2007	887	1.4	FAF87R57	4
11	209	129.14	1.8	F 47	4	1.8	1765	780	1.6	F 87R57	4
12	195	120.70	1.9	FF 47	4	2.1	1525	674	1.8	FF 87R57	4
13	168	104.33	2.2			2.3	1378	609	2.0		
16	143	88.65	2.6			2.7	1165	515	2.4		
11	207	128.51	0.9			3.1	1023	452	2.8		
12	190	117.88	1.0			1.7	1833	810	0.77		
14	162	100.36	1.2			2.0	1606	710	0.88		
16	140	86.53	1.3			2.3	1357	600	1.04	FA 77R37	4
17	130	80.65	1.4			2.6	1188	525	1.19	FAF77R37	4
20	114	70.50	1.7			3.0	1061	469	1.33	F 77R37	4
21	107	66.09	1.8			3.4	932	412	1.51	FF 77R37	4
24	94	58.32	2.0			3.9	808	357	1.75		
25	88	54.54	2.1			4.4	710	314	1.98		
27	83	51.70	2.3			3.3	966	427	0.80		
30	76	47.02	2.5			3.8	828	366	0.93	FA 67R37	4
32	71	43.83	2.7			4.3	731	323	1.05	FAF67R37	4
36	62	38.31	3.0	FA 37	4	4.8	656	290	1.17	F 67R37	4
39	58	35.91	3.2	FAF37	4	5.4	581	257	1.33	FF 67R37	4
44	51	31.69	3.7	F 37	4	6.3	498	220	1.55		
49	45	28.09	4.1	FF 37	4	5.3	593	262	0.95		
58	39	23.88	4.9			5.6	563	249	1.00		
59	38	23.63	4.9			6.2	511	226	1.10	FA 57R37	4
68	33	20.57	5.7			7.0	452	200	1.25	FAF57R37	4
72	31	19.27	6.0			7.1	446	197	1.27	F 57R37	4
82	27	17.03	6.8			7.7	410	181	1.38	FF 57R37	4
88	26	15.81	7.4			8.4	376	166	1.50		
97	23	14.33	8.1			9.1	344	152	1.64		
108	21	12.87	9.0			10	303	134	1.86		
125	18	11.08	10								
133	17	10.42	10								
155	14	8.97	11								
185	12	7.51	11								

F



重泰减速机

ZHONG TAI REDUCER

品质铸就品牌

F

输出转速 Output speed r/min	输出扭矩 Output torque Nm	传动比 Ratio i	使用系数 Service factor f _B	机型号 Type Type	极数 Pole p	输出转速 Output speed r/min	输出扭矩 Output torque Nm	传动比 Ratio i	使用系数 Service factor f _B	机型号 Type Type	极数 Pole p
0.37kW						0.37kW					
8.0	391	173	0.96	FA 47R17	4	32	105	43.83	1.80		
9.5	330	146	1.14	FAF47R17	4	36	92	38.31	2.1		
11	292	129	1.29	F 47R17	4	39	86	35.91	2.2		
				FF 47R17	4	44	76	31.69	2.5		
2.4	1400	271.92	2.0	FA 87	8	49	67	28.09	2.8		
2.5	1313	254.93	2.1	FAF87	8	58	57	23.88	3.3		
2.8	1177	228.57	2.4	F 87	8	59	56	23.63	3.3		
3.3	1014	196.85	2.8	FF 87	8	68	49	20.57	3.8		
						72	46	19.27	4.1		
3.1	1063	271.92	2.7	FA 87	6	82	41	17.03	4.6	FA 37	4
3.3	996	254.93	2.8	FAF87	6	88	38	15.81	5.0	FAF37	4
3.7	893	228.57	3.2	F 87	6	97	34	14.33	5.5	F 37	4
				FF 87	6	108	31	12.87	6.1	FF 37	4
3.8	882	225.79	1.6	FA 77	6	125	26	11.08	6.7		
4.3	775	198.31	1.8	FAF77	6	133	25	10.42	7.0		
4.5	736	188.40	1.9	F 77	6	155	21	8.97	7.6		
5.1	651	166.47	2.2	FF 77	6	185	18	7.51	7.7		
6.0	556	142.27	2.5			204	16	6.81	8.1		
						227	15	6.11	8.7		
4.9	673	281.71	2.1	FA 77	4	264	13	5.27	9.3		
5.3	628	262.93	2.2	FAF77	4	281	12	4.95	9.5		
6.2	540	225.79	2.6	F 77	4	326	10	4.26	10		
7.0	474	198.31	3.0	FF 77	4						
4.4	764	195.39	1.01	FA 67	6	0.55kW					
5.0	668	170.85	1.15	FAF67	6	0.22	21141	6286	0.80		
5.2	634	162.31	1.22	F 67	6	0.26	18174	5404	0.93	FA 157R97	4
6.0	556	142.40	1.4	FF 67	6	0.50	9336	2776	1.81	FAF157R97	4
7.0	472	120.79	1.6			0.57	8162	2427	2.1	F 157R97	4
						0.83	5630	1674	3.0	FF 157R97	4
6.1	547	228.99	1.41			1.1	4399	1308	3.8		
7.1	467	195.39	1.65	FA 67	4	1.2	3931	1169	4.3		
8.1	408	170.85	1.89	FAF67	4						
8.6	388	162.31	1.99	F 67	4	0.36	13009	3868	0.87	FA 127R77	4
9.8	340	142.40	2.3	FF 67	4	0.41	11445	3403	0.99	FAF127R77	4
12	289	120.79	2.7			0.47	10046	2987	1.12	F 127R77	4
										FF 127R77	4
5.4	614	157.09	0.92	FA 57	6	0.59	7967	2369	0.92		
6.2	532	136.16	1.06	FAF57	6	0.67	6955	2068	1.06		
6.7	497	127.27	1.13	F 57	6	0.76	6141	1826	1.20		
7.7	430	110.01	1.31	FF 57	6	0.87	5371	1597	1.37	FA 107R77	4
						0.99	4712	1401	1.56	FAF107R77	4
7.0	477	199.70	1.18			1.19	3921	1166	1.88	F 107R77	4
7.6	439	183.60	1.29			1.28	3656	1087	2.0	FF 107R77	4
8.8	375	157.09	1.50	FA 57	4	1.46	3195	950	2.3		
10	325	136.16	1.73	FAF57	4	1.67	2805	834	2.6		
11	304	127.27	1.85	F 57	4	2.17	2152	640	3.4		
13	263	110.01	2.1	FF 57	4						
15	223	93.47	2.5			1.04	4507	1340	0.90		
17	199	83.46	2.8			1.18	3975	1182	1.02		
						1.35	3471	1032	1.16		
9	356	148.98	1.06			1.5	3050	907	1.33	FA 97R57	4
11	309	129.14	1.22	FA 47	4	1.7	2677	796	1.5	FAF97R57	4
13	249	104.33	1.51	FAF47	4	2.0	2354	700	1.7	F 97R57	4
16	212	88.65	1.77	F 47	4	2.3	2055	611	2.0	FF 97R57	4
18	189	79.15	2.0	FF 47	4	2.6	1796	534	2.3		
21	162	67.61	2.3			2.9	1587	472	2.5		
21	155	64.89	2.4			3.4	1379	410	2.9		
						3.8	1234	367	3.3		
16	207	86.53	0.91			1.6	2983	887	0.95		
17	193	80.65	0.98			1.8	2623	780	1.08	FA 87R57	4
20	168	70.50	1.12	FA 37	4	2.1	2267	674	1.24	FAF87R57	4
21	158	66.09	1.19	FAF37	4	2.3	2048	609	1.38	F 87R57	4
24	139	58.32	1.35	F 37	4	2.7	1732	515	1.63	FF 87R57	4
25	130	54.54	1.44	FF 37	4	3.1	1520	452	1.86		
27	124	51.70	1.52			4.0	1160	345	2.4		
30	112	47.02	1.67								



重泰减速机

ZHONG TAI REDUCER

品质铸就品牌

输出转速 Output speed r/min	输出扭矩 Output torque Nm	传动比 Ratio i	使用系数 Service factor f _B	机型号 Type Type	极数 Pole p	输出转速 Output speed r/min	输出扭矩 Output torque Nm	传动比 Ratio i	使用系数 Service factor f _B	机型号 Type Type	极数 Pole p
0.55kW						0.55kW					
2.6	1766	525	0.80			21	230	64.89	1.63	FA 47	4
3.0	1577	469	0.89	FA 77R37	4	25	199	56.09	1.89	FAF47	4
3.4	1386	412	1.02	FAF77R37	4	29	169	47.66	2.2	F 47	4
3.9	1201	357	1.17	F 77R37	4	33	151	42.55	2.5	FF 47	4
4.4	1056	314	1.34	FF 77R37	4						
5.4	864	257	0.89	FA 67R37	4	24	207	58.32	0.91		
6.3	740	220	1.04	FAF67R37	4	25	194	54.54	0.97		
7.1	659	196	1.17	F 67R37	4	27	184	51.70	1.02		
8.3	562	167	1.37	FF 67R37	4	30	167	47.02	1.13		
						32	156	43.83	1.21		
						36	136	38.31	1.38		
2.4	2039	276.64	1.98	FA 97	8	39	128	35.91	1.47		
2.6	1878	254.79	2.2	FAF97	8	44	113	31.69	1.67		
3.0	1668	226.34	2.4	F 97	8	49	100	28.09	1.88		
						58	85	23.88	2.2		
						59	84	23.63	2.2		
2.5	2004	271.92	1.41	FA 87	8	68	73	20.57	2.6	FA 37	4
2.6	1875	254.93	1.50	FAF87	8	72	68	19.27	2.7	FAF37	4
2.9	1684	228.57	1.67	F 87	8	82	60	17.03	3.1	F 37	4
3.4	1450	196.85	1.94	FF 87	8	97	51	14.33	3.7	FF 37	4
						108	46	12.87	4.1		
3.3	1517	271.92	1.86	FA 87	6	125	39	11.08	4.5		
3.5	1422	254.93	1.98	FAF87	6	133	37	10.42	4.7		
3.9	1275	228.57	2.2	F 87	6	155	32	8.97	5.1		
4.5	1098	196.85	2.6	FF 87	6	174	28	8.01	5.2		
4.9	998	178.95	2.8			185	27	7.51	5.4		
						204	24	6.81	5.6		
3.9	1260	225.79	1.12	FA 77	6	227	22	6.11	5.8		
4.5	1106	198.31	1.27	FAF77	6	264	19	5.27	6.3		
4.7	1051	188.40	1.34	F 77	6	281	18	4.95	6.4		
5.3	929	166.47	1.52	FF 77	6	326	15	4.26	6.8		
6.2	794	142.27	1.78			365	14	3.81	7.3		
6.8	728	130.42	1.94								
						0.75kW					
6.2	802	225.79	1.76			0.50	12731	2776	1.33	FA 157R97	4
7.0	704	198.31	2.0			0.57	11130	2427	1.52	FAF157R97	4
7.4	669	188.40	2.1	FA 77	4	0.83	7677	1674	2.2	F 157R97	4
8.3	591	166.47	2.4	FAF77	4	1.1	5999	1308	2.8	FF 157R97	4
9.8	505	142.27	2.8	F 77	4	1.2	5361	1169	3.2		
11	463	130.42	3.0	FF 77	4						
12	407	114.45	3.5			0.47	13699	2987	0.82		
13	385	108.46	3.7			0.52	12350	2693	0.91	FA 127R77	4
15	337	94.93	4.2			0.59	10896	2376	1.04	FAF127R77	4
						0.68	9420	2054	1.20	F 127R77	4
7.1	694	195.39	1.11			0.77	8246	1798	1.37	FF 127R77	4
8.1	607	170.85	1.27			0.86	7425	1619	1.52		
8.6	577	162.31	1.34	FA 67	4						
9.8	506	142.40	1.52	FAF67	4	0.76	8374	1826	0.88		
12	429	120.79	1.80	F 67	4	0.88	7241	1597	1.02		
13	387	109.04	2.0	FF 67	4	0.99	6425	1401	1.15	FA 107R77	4
14	341	95.94	2.3			1.1	5700	1243	1.29	FAF107R77	4
15	322	90.59	2.4			1.3	4985	1087	1.48	F 107R77	4
18	277	77.97	2.8			1.5	4357	950	1.69	FF 107R77	4
						1.7	3825	834	1.93		
8.8	558	157.09	1.01			2.2	2875	627	2.6		
10	484	136.16	1.17			3.3	1958	427	3.8		
11	452	127.27	1.25	FA 57	4						
13	391	110.01	1.44	FAF57	4	1.3	4733	1032	0.85		
15	332	93.47	1.70	F 57	4	1.5	4160	907	0.97		
17	296	83.46	1.90	FF 57	4	1.7	3651	796	1.1	FA 97R57	4
19	260	73.16	2.2			2.0	3210	700	1.3	FAF97R57	4
20	243	68.38	2.3			2.3	2802	611	1.4	F 97R57	4
24	210	59.10	2.7			2.6	2449	534	1.7	FF 97R57	4
						2.9	2165	472	1.9		
13	371	104.33	1.01	FA 47	4	3.4	1880	410	2.1		
16	315	88.65	1.19	FAF47	4	3.8	1683	367	2.4		
18	281	79.15	1.34	F 47	4						
21	240	67.61	1.57	FF 47	4						

F



重泰减速机

ZHONG TAI REDUCER

品质铸就品牌

输出转速 Output speed r/min	输出扭矩 Output torque Nm	传动比 Ratio i	使用系数 Service factor f _s	机型号 Type Type	极数 Pole p	输出转速 Output speed r/min	输出扭矩 Output torque Nm	传动比 Ratio i	使用系数 Service factor f _s	机型号 Type Type	极数 Pole p
0.75kW						0.75kW					
2.1	3091	674	0.91			19	354	73.16	1.59	FA 57	4
2.3	2793	609	1.01	FA 87R57	4	20	331	68.38	1.70	FAF57	4
2.7	2362	515	1.19	FAF87R57	4	24	286	59.10	1.97	F 57	4
3.1	2073	452	1.36	F 87R57	4	28	243	50.22	2.3	FF 57	4
4.0	1582	345	1.78	FF 87R57	4	31	217	44.84	2.6		
3.9	1637	357	0.86	FA 77R37	4	17	386	79.72	0.97		
4.4	1440	314	0.98	FAF77R37	4	20	330	68.09	1.14		
5.1	1247	272	1.13	F 77R37	4	21	317	65.36	1.19	FA 47	4
				FF 77R37	4	25	272	56.09	1.38	FAF47	4
						29	231	47.66	1.63	F 47	4
2.7	2519	255.25	2.9	FA 107	8	33	206	42.55	1.82	FF 47	4
				FAF107	8	38	176	36.34	2.1		
				F 107	8	41	165	34.04	2.3		
				FF 107	8	48	139	28.67	2.7		
2.5	2739	276.64	1.5	FA 97	8	30	228	47.02	0.83		
2.7	2523	254.79	1.6	FAF97	8	32	212	43.83	0.89		
3.0	2241	226.34	1.8	F 97	8	36	186	38.31	1.01		
				FF 97	8	39	174	35.91	1.08		
3.3	2047	276.64	2.0	FA 97	6	44	153	31.69	1.22		
3.6	1885	254.79	2.1	FAF97	6	49	136	28.09	1.38		
4.0	1675	226.34	2.4	F 97	6	58	116	23.88	1.63		
				FF 97	6	59	114	23.63	1.6		
3.3	2012	271.92	1.40			68	100	20.57	1.9		
3.6	1886	254.93	1.50	FA 87	6	72	93	19.27	2.0	FA 37	4
4.0	1691	228.57	1.67	FAF87	6	82	82	17.03	2.3	FAF37	4
4.6	1456	196.85	1.94	F 87	6	97	69	14.33	2.7	F 37	4
5.1	1324	178.95	2.1	FF 87	6	108	62	12.87	3.0	FF 37	4
5.7	1181	159.61	2.4			125	54	11.08	3.3		
5.1	1317	271.92	2.1	FA 87	4	133	50	10.42	3.4		
5.4	1235	254.93	2.3	FAF87	4	155	43	8.97	3.8		
6.1	1107	228.57	2.5	F 87	4	204	33	6.81	4.0		
				FF 87	4	227	30	6.11	4.3		
4.6	1467	198.31	0.96			264	26	5.27	4.6		
4.8	1394	188.40	1.01	FA 77	6	281	24	4.95	4.7		
5.5	1232	166.47	1.14	FAF77	6	326	21	4.26	5.0		
6.4	1053	142.27	1.34	F 77	6	365	18	3.81	5.3		
7.0	965	130.42	1.46	FF 77	6	1.1kW					
6.2	1094	225.79	1.29			0.50	18539	2776	0.91		
7.0	961	198.31	1.47			0.58	16208	2427	1.04		
7.4	913	188.40	1.55	FA 77	4	0.64	14592	2185	1.16		
8.3	806	166.47	1.75	FAF77	4	0.72	12982	1944	1.30	FA 157R97	4
9.8	689	142.27	2.0	F 77	4	0.84	11179	1674	1.51	FAF157R97	4
11	632	130.42	2.2	FF 77	4	1.1	8735	1308	1.94	F 157R97	4
12	554	114.45	2.5			1.2	7807	1169	2.2	FF 157R97	4
13	525	108.46	2.7			1.5	6364	953	2.7		
8.1	828	170.85	0.93			1.7	5643	845	3.0		
8.6	786	162.31	0.98			3.1	2978	446	5.7		
9.8	690	142.40	1.12	FA 67	4	4.7	2010	301	8.4		
12	585	120.79	1.32	FAF67	4	0.68	13717	2054	0.82		
13	528	109.04	1.46	F 67	4	0.78	12007	1798	0.94	FA 127R77	4
14	465	95.94	1.66	FF 67	4	0.86	10812	1619	1.04	FAF127R77	4
15	439	90.59	1.76			1.0	9356	1401	1.21	F 127R77	4
18	378	77.97	2.0			1.1	8214	1230	1.37	FF 127R77	4
21	320	66.13	2.4			1.3	7246	1085	1.56		
23	289	59.70	2.7			1.1	8301	1243	0.89		
11	616	127.27	0.91	FA 57	4	1.3	7259	1087	1.02	FA 107R77	4
13	533	110.01	1.06	FAF57	4	1.5	6344	950	1.16	FAF107R77	4
15	453	93.47	1.25	F 57	4	1.7	5570	834	1.32	F 107R77	4
17	404	83.46	1.40	FF 57	4	1.9	4915	736	1.50	FF 107R77	4
						2.2	4274	640	1.72		

F



重泰减速机

ZHONG TAI REDUCER

品质铸就品牌

输出转速 Output speed r/min	输出扭矩 Output torque Nm	传动比 Ratio i	使用系数 Service factor f _B	机型号 Type Type	极数 Pole p	输出转速 Output speed r/min	输出扭矩 Output torque Nm	传动比 Ratio i	使用系数 Service factor f _B	机型号 Type Type	极数 Pole p
1.1kW						1.1kW					
2.0	4675	700	0.86			17	589	83.46	0.96		
2.3	4080	611	0.99	FA 97R57	4	19	516	73.16	1.09		
2.6	3566	534	1.13	FAF97R57	4	20	482	68.38	1.17	FA 57	4
3.0	3152	472	1.28	F 97R57	4	24	417	59.10	1.35	FAF57	4
3.4	2738	410	1.48	FF 97R57	4	28	354	50.22	1.59	F 57	4
3.8	2451	367	1.65			31	316	44.84	1.78	FF 57	4
3.1	3019	452	0.93	FA 87R57	4	37	270	38.30	2.1		
4.1	2304	345	1.22	FAF87R57	4	39	253	35.87	2.2		
4.7	2003	300	1.41	F 87R57	4	46	213	30.22	2.6		
5.6	1663	249	1.70	FF 87R57	4	25	396	56.09	0.95		
2.7	3707	255.25	1.95	FA 107	8	29	336	47.66	1.12		
3.2	3123	215.04	2.3	FAF107	8	33	300	42.55	1.25		
3.4	2894	199.31	2.5	F 107	8	39	256	36.34	1.47	FA 47	4
3.8	2594	178.64	2.8	FF 107	8	41	240	34.04	1.57	FAF47	4
3.3	3002	276.64	1.35	FA 97	6	46	216	30.64	1.74	F 47	4
3.6	2765	254.79	1.46	FAF97	6	48	205	29.11	1.83	FF 47	4
4.0	2456	226.34	1.65	F 97	6	49	202	28.67	1.86		
4.8	2045	188.50	2.0	FF 97	6	55	180	25.54	2.1		
5.2	1908	175.83	2.1			65	153	21.66	2.5		
5.1	1951	276.64	2.1	FA 97	4	72	138	19.56	2.7		
5.5	1797	254.79	2.2	FAF97	4	44	224	31.69	0.84		
6.2	1596	226.34	2.5	F 97	4	50	198	28.09	0.95		
3.3	2951	271.92	0.96	FA 87	6	59	168	23.88	1.12		
3.6	2766	254.93	1.02	FAF87	6	68	145	20.57	1.30		
4.0	2480	228.57	1.14	F 87	6	73	136	19.27	1.38		
4.6	2136	196.85	1.32	FF 87	6	82	120	17.03	1.57		
5.1	1942	178.95	1.45			98	101	14.33	1.86		
5.7	1732	159.61	1.63			109	91	12.87	2.1	FA 37	4
5.2	1911	271.92	1.48	FA 87	4	126	78	11.08	2.3	FAF37	4
5.5	1798	254.93	1.57	FAF87	4	134	73	10.42	2.4	F 37	4
6.1	1612	228.57	1.75	F 87	4	156	63	8.97	2.6	FF 37	4
7.1	1388	196.85	2.0	FF 87	4	175	56	8.01	2.7		
7.8	1262	178.95	2.2			206	48	6.81	2.8		
8.8	1126	159.61	2.5			229	43	6.11	2.9		
10	946	134.16	3.0			266	37	5.27	3.2		
11	870	123.29	3.2			283	35	4.95	3.2		
7.1	1399	198.31	1.01	FA 77	4	329	30	4.26	3.4		
7.4	1329	188.40	1.06	FAF77	4	367	27	3.81	3.7		
8.4	1174	166.47	1.20	F 77	4	1.5kW					
9.8	1003	142.27	1.41	FF 77	4	0.58	22102	2427	0.77		
11	920	130.42	1.53			0.64	19898	2185	0.85		
12	807	114.45	1.75			0.72	17703	1944	0.96		
13	765	108.46	1.84			0.84	15244	1674	1.11	FA 157R97	4
15	670	94.93	2.1			1.1	11911	1308	1.42	FAF157R97	4
16	603	85.52	2.3			1.2	10646	1169	1.59	F 157R97	4
19	529	75.02	2.7			1.5	8679	953	1.95	FF 157R97	4
12	853	120.79	0.9	FA 67	4	1.7	7695	845	2.2		
13	769	109.04	1.0	FAF67	4	3.1	4062	446	4.2		
15	677	95.94	1.1	F 67	4	4.7	2741	301	6.2		
15	639	90.59	1.2	FF 67	4	0.86	14744	1619	0.77		
18	550	77.97	1.4			1.0	12758	1401	0.88	FA 127R77	4
21	466	66.13	1.7			1.1	11201	1230	1.01	FAF127R77	4
23	421	59.70	1.8			1.3	9881	1085	1.14	F 127R77	4
27	371	52.53	2.1			1.5	8533	937	1.32	FF 127R77	4
28	350	49.60	2.2			1.7	7531	827	1.50		
33	298	42.23	2.6			1.9	6675	733	1.69		
36	271	38.38	2.7			2.2	5828	640	1.94		
42	234	33.24	3.0			1.5	8651	950	0.83	FA 107R77	4
						1.7	7595	834	0.95	FAF107R77	4
						1.9	6702	736	1.08	F 107R77	4
						2.2	5710	627	1.26	FF 107R77	4

F



重泰减速机

ZHONG TAI REDUCER

品质铸就品牌

F

输出转速 Output speed r/min	输出扭矩 Output torque Nm	传动比 Ratio i	使用系数 Service factor f _B	机型号 Type Type	极数 Pole p	输出转速 Output speed r/min	输出扭矩 Output torque Nm	传动比 Ratio i	使用系数 Service factor f _B	机型号 Type Type	极数 Pole p
1.5kW						1.5kW					
2.5	5100	560	1.42	FA 107R77	4	15	871	90.59	0.88		
2.9	4453	489	1.62	FAF107R77	4	18	750	77.97	1.03		
3.3	3889	427	1.86	F 107R77	4	21	636	66.13	1.21		
3.8	3369	370	2.1	FF 107R77	4	23	574	59.70	1.34		
2.6	4863	534	0.83	FA 97R57	4	27	505	52.53	1.53	FA 67	4
3.0	4298	472	0.94	FAF97R57	4	28	477	49.60	1.62	FAF67	4
3.4	3734	410	1.08	F 97R57	4	33	406	42.23	1.90	F 67	4
3.8	3342	367	1.21	FF 97R57	4	36	369	38.38	1.99	FF 67	4
4.1	3142	345	0.90	FA 87R57	4	39	349	36.30	2.2		
4.7	2732	300	1.03	FAF87R57	4	44	309	32.08	2.5		
5.6	2268	249	1.24	F 87R57	4	51	264	27.41	2.9		
				FF 87R57	4	56	242	25.13	3.2		
2.7	4981	255.25	1.48	FA 107	8	24	568	59.10	0.99	FA 57	4
3.2	4197	215.04	1.76	FAF107	8	28	483	50.22	1.17	FAF57	4
3.5	3890	199.31	1.89	F 107	8	31	431	44.84	1.31	F 57	4
3.9	3486	178.64	2.1	FF 107	8	37	368	38.30	1.53	FF 57	4
3.6	3736	255.25	2.0	FA 107	6	39	345	35.87	1.63		
4.3	3147	215.04	2.3	FAF107	6	46	291	30.22	1.94		
4.6	2917	199.31	2.5	F 107	6	33	409	42.55	0.92		
5.2	2615	178.64	2.8	FF 107	6	39	350	36.34	1.08		
3.3	4049	276.64	1.00	FA 97	6	41	327	34.04	1.15		
3.6	3729	254.79	1.08	FAF97	6	46	295	30.64	1.28	FA 47	4
4.1	3313	226.34	1.22	F 97	6	48	280	29.11	1.34	FAF47	4
4.9	2759	188.50	1.47	FF 97	6	49	276	28.67	1.36	F 47	4
5.2	2574	178.83	1.57			55	246	25.54	1.53	FF 47	4
5.1	2661	276.64	1.52	FA 97	4	65	208	21.66	1.80		
5.5	2451	254.79	1.65	FAF97	4	72	188	19.56	2.0		
6.2	2177	226.34	1.86	F 97	4	81	166	17.21	2.3		
7.4	1813	188.50	2.2	FF 97	4	86	156	16.25	2.4		
8.0	1691	178.83	2.4			101	133	13.83	2.8		
5.2	2615	271.92	1.08			68	198	20.57	0.95		
5.5	2452	254.93	1.15	FA 87	4	73	185	19.27	1.01		
6.1	2198	228.57	1.28	FAF87	4	82	164	17.03	1.15		
7.1	1893	196.85	1.49	F 87	4	98	138	14.33	1.36		
7.8	1721	178.95	1.63	FF 87	4	109	124	12.87	1.52		
8.8	1535	159.61	1.84			126	107	11.08	1.68	FA 37	4
10	1290	134.16	2.2			134	100	10.42	1.74	FAF37	4
13	1053	109.49	2.7			156	86	8.97	1.91	F 37	4
14	942	97.89	3.0			175	77	8.01	2.1	FF 37	4
8.4	1601	166.47	0.88			206	66	6.81	2.0		
9.8	1368	142.27	1.03			229	59	6.11	2.2		
11	1254	130.42	1.12			266	51	5.27	2.3		
12	1101	114.45	1.28			283	48	4.95	2.4		
13	1043	108.46	1.35			329	41	4.26	2.5		
15	913	94.93	1.54			367	37	3.81	2.7		
16	823	85.52	1.71	FA 77	4	2.2kW					
19	722	75.02	1.95	FAF77	4	1.00	18699	1420	0.90		
19	695	72.29	2.0	F 77	4	1.09	17224	1308	0.98		
21	637	66.28	2.2	FF 77	4	1.21	15394	1169	1.10		
24	559	58.16	2.5			1.49	12549	953	1.35		
25	530	55.12	2.7			1.68	11127	845	1.52	FA 157R97	4
29	464	48.24	3.0			1.86	10061	764	1.68	FAF157R97	4
32	418	43.46	3.0			2.1	8954	680	1.89	F 157R97	4
37	367	38.12	3.4			2.5	7585	576	2.2	FF 157R97	4
38	352	36.52	3.8			3.2	5873	446	2.9		
44	303	31.45	4.3			4.7	3964	301	4.3		
						5.2	3582	272	4.7		
						6.1	3042	231	5.6		
						7.2	2581	196	6.6		
						1.31	14288	1085	0.79	FA 127R77	4
						1.52	12339	937	0.91	FAF127R77	4
						1.72	10890	827	1.04	F 127R77	4
						1.94	9652	733	1.17	FF 127R77	4



重泰减速机

ZHONG TAI REDUCER

品质铸就品牌

输出转速 Output speed r/min	输出扭矩 Output torque Nm	传动比 Ratio i	使用系数 Service factor f _B	机型号 Type Type	极数 Pole p	输出转速 Output speed r/min	输出扭矩 Output torque Nm	传动比 Ratio i	使用系数 Service factor f _B	机型号 Type Type	极数 Pole p
2.2kW						2.2kW					
2.22	8428	640	1.34	FA 127R77	4	26	767	55.12	1.84		
2.62	7137	542	1.58	FAF127R77	4	29	671	48.24	2.1	FA 77	4
2.90	6439	489	1.75	F 127R77	4	33	604	43.46	2.1	FAF77	4
3.36	5570	428	2.0	FF 127R77	4	39	509	36.52	2.3	F 77	4
						45	438	31.45	3.0	FF 77	4
2.3	8256	627	0.89			49	400	28.59	3.4		
2.5	7374	560	1.00	FA 107R77	4	56	355	25.50	4.0		
2.9	6439	489	1.14	FAF107R77	4						
3.3	5623	427	1.31	F 107R77	4	24	830	59.70	0.93		
3.9	4767	362	1.55	FF 107R77	4	27	731	52.53	1.06		
4.3	4306	327	1.71			29	690	49.60	1.12		
						34	587	42.23	1.31		
3.9	4833	367	0.84	FA 97R57	4	37	534	38.38	1.37	FA 67	4
4.9	3792	288	1.07	FAF97R57	4	43	462	33.24	1.50	FAF67	4
5.7	3253	247	1.24	F 97R57	4	44	446	32.08	1.73	F 67	4
						52	381	27.41	2.0	FF 67	4
						57	350	25.13	2.2		
2.8	7100	255.25	1.02	FA 107	8	64	307	22.05	2.5		
3.3	5982	215.04	1.21	FAF107	8	68	291	20.90	2.7		
3.6	5544	199.31	1.30	F 107	8	78	254	18.29	3.0		
4.0	4969	178.64	1.45	FF 107	8						
						32	624	44.84	0.90		
3.7	5363	255.25	1.35	FA 107	6	37	533	38.30	1.06		
4.4	4518	215.04	1.60	FAF107	6	40	499	35.87	1.13	FA 57	4
4.7	4188	199.31	1.72	F 107	6	47	420	30.22	1.32	FAF57	4
5.3	3753	178.64	1.92	FF 107	6	57	347	24.96	1.56	F 57	4
						67	294	21.17	1.92	FF 57	4
5.6	3550	255.25	2.0	FA 107	4	74	266	19.11	2.1		
6.6	2991	215.04	2.4	FAF107	4	84	234	16.81	2.4		
7.1	2772	199.31	2.6	F 107	4	89	221	15.88	2.6		
7.9	2485	178.64	2.9	FF 107	4						
						56	355	25.54	1.06		
4.2	4755	226.34	0.85	FA 97	6	66	301	21.66	1.25		
5.0	3960	188.50	1.02	FAF97	6	73	272	19.56	1.38		
5.3	3694	175.83	1.09	F 97	6	83	239	17.21	1.57	FA 47	4
6.0	3302	157.16	1.22	FF 97	6	87	226	16.25	1.66	FAF47	4
						103	192	13.83	1.95	F 47	4
5.1	3848	276.64	1.05			113	175	12.57	2.2	FF 47	4
5.6	3544	254.79	1.14			130	151	10.89	2.5		
6.3	3148	226.34	1.28	FA 97	4	156	126	9.08	2.5		
7.5	2622	188.50	1.54	FAF97	4						
8.1	2445	175.83	1.65	F 97	4	99	199	14.33	0.94		
9.0	2186	157.16	1.85	FF 97	4	110	179	12.87	1.05		
10	1968	141.47	2.1			128	154	11.08	1.16		
11	1782	128.12	2.3			136	145	10.42	1.20		
						158	125	8.97	1.32	FA 37	4
7.2	2738	196.85	1.03			177	111	8.01	1.39	FAF37	4
7.9	2489	178.95	1.13			209	95	6.81	1.43	F 37	4
8.9	2220	159.61	1.27			232	85	6.11	1.49	FF 37	4
11	1866	134.16	1.51			269	73	5.27	1.60		
12	1715	123.29	1.64	FA 87	4	287	69	4.95	1.64		
13	1523	109.49	1.85	FAF87	4	333	59	4.26	1.75		
15	1361	97.89	2.1	F 87	4	373	53	3.81	1.86		
16	1224	88.01	2.3	FF 87	4						
19	1062	76.39	2.7			3kW					
21	951	68.40	3.0			1.2	20991	1169	0.81		
25	789	56.75	3.6			1.5	17113	953	0.99		
28	699	50.29	4.0			1.7	15173	845	1.12	FA 157R97	4
31	629	45.22	4.2			1.9	13719	764	1.23	FAF157R97	4
						2.1	12211	680	1.39	F 157R97	4
12	1592	114.45	0.89			2.5	10343	576	1.64	FF 157R97	4
13	1508	108.46	0.93	FA 77	4	3.2	8009	446	2.1		
15	1320	94.93	1.07	FAF77	4	4.7	5405	304	3.1		
17	1189	85.52	1.19	F 77	4	5.2	4884	272	3.5		
19	1043	75.02	1.35	FF 77	4	6.1	4148	231	4.1		
21	922	66.28	1.53			7.2	3520	196	4.8		
24	809	58.16	1.74								

F



F

输出转速 Output speed r/min	输出扭矩 Output torque Nm	传动比 Ratio i	使用系数 Service factor f _B	机型号 Type Type	极数 Pole p	输出转速 Output speed r/min	输出扭矩 Output torque Nm	传动比 Ratio i	使用系数 Service factor f _B	机型号 Type Type	极数 Pole p
3kW						3kW					
1.9	13162	733	0.86	FA 127R77	4	57	473	24.96	1.19		
2.2	11492	640	0.98	FAF127R77	4	67	401	21.17	1.40		
2.6	9733	542	1.16	F 127R77	4	74	362	19.11	1.56	FA 57	4
2.9	8781	489	1.28	FF 127R77	4	84	319	16.81	1.77	FAF57	4
3.3	7668	427	0.96	FA 107R77	4	89	301	15.88	1.87	F 57	4
3.9	6500	362	1.13	FAF107R77	4	105	256	13.52	2.2	FF 57	4
4.3	5872	327	1.26	F 107R77	4	116	233	12.29	2.4		
5.0	5118	285	1.44	FF 107R77	4	133	202	10.64	2.8		
3.8	7161	255.25	1.03	FA 107	6	73	371	19.56	1.01		
4.5	6033	215.04	1.22	FAF107	6	83	326	17.21	1.15	FA 47	4
4.8	5591	199.31	1.32	F 107	6	87	308	16.25	1.22	FAF47	4
5.4	5011	178.64	1.47	FF 107	6	103	262	13.83	1.43	F 47	4
5.6	4841	255.25	1.52	FA 107	4	113	238	12.57	1.58	FF 47	4
6.6	4078	215.04	1.81	FAF107	4	130	207	10.89	1.80		
7.1	3780	199.31	1.95	F 107	4	156	172	9.08	1.82		
7.9	3388	178.64	2.2	FF 107	4	128	210	11.08	0.85		
8.8	3059	161.28	2.4			136	198	10.42	0.88		
6.3	4293	226.34	0.94			158	170	8.97	0.97	FA 37	4
7.5	3575	188.50	1.13			177	152	8.01	1.02	FAF37	4
8.1	3335	175.83	1.21	FA 97	4	209	129	6.81	1.05	F 37	4
9.0	2981	157.16	1.36	FAF97	4	232	116	6.11	1.10	FF 37	4
10	2683	141.47	1.51	F 97	4	269	100	5.27	1.18		
11	2430	128.12	1.66	FF 97	4	287	94	4.95	1.20		
12	2155	113.61	1.88			333	81	4.26	1.28		
14	1948	102.72	2.1			373	72	3.81	1.37		
16	1721	90.77	2.3			4kW					
11	2544	134.16	1.11			1.7	19950	845	0.85		
12	2338	123.29	1.21			1.9	18038	764	0.94		
13	2077	109.49	1.36			2.1	16055	680	1.05	FA 157R97	4
15	1857	97.89	1.52			2.5	13599	576	1.24	FAF157R97	4
16	1669	88.01	1.69	FA 87	4	3.2	10530	446	1.61	F 157R97	4
19	1449	76.39	1.9	FAF87	4	4.8	7107	304	2.4	FF 157R97	4
21	1297	68.40	2.2	F 87	4	5.3	6422	272	2.6		
25	1076	56.75	2.6	FF 87	4	6.2	5454	231	3.1		
28	954	50.29	2.9			7.3	4628	196	3.7		
17	1622	85.52	0.87			2.7	12796	542	0.88	FA 127R77	4
19	1423	75.02	0.99			2.9	11545	489	0.98	FAF127R77	4
21	1257	66.28	1.12			3.4	9987	423	1.13	F 127R77	4
24	1103	58.16	1.28			3.9	8759	371	1.29	FF 127R77	4
26	1045	55.12	1.35			4.4	7720	327	0.94	FA 107R77	4
29	915	48.24	1.5	FA 77	4	5.1	6729	285	1.07	FAF107R77	4
33	824	43.46	1.54	FAF77	4	6.5	5218	221	1.38	F 107R77	4
37	723	38.12	1.71	F 77	4					FF 107R77	4
39	694	36.52	1.95	FF 77	4						
45	598	31.45	2.2			4.2	8594	172.33	1.31	FA 127	8
49	545	28.59	2.5			4.6	7721	154.81	1.46	FAF127	8
56	484	25.50	2.9			5.7	6269	125.71	1.80	F 127	8
66	406	21.43	3.5							FF 127	8
33	819	43.20	0.94			5.6	6365	255.25	1.16		
36	745	39.26	0.98			6.7	5363	215.04	1.37	FA 107	4
42	645	34.01	1.08			7.2	4970	199.31	1.48	FAF107	4
44	608	32.08	1.27			8.1	4455	178.64	1.65	F 107	4
52	520	27.41	1.48	FA 67	4	8.9	4022	161.28	1.83	FF 107	4
57	477	25.13	1.62	FAF67	4	9.8	3653	146.49	2.02		
64	418	22.05	1.84	F 67	4	11	3241	129.97	2.3		
68	396	20.90	1.94	FF 67	4	12	2941	117.94	2.5		
78	347	18.29	2.2			14	2528	101.38	2.9		
86	313	16.48	2.5								
98	274	14.46	2.8								



输出转速 Output speed r/min	输出扭矩 Output torque Nm	传动比 Ratio i	使用系数 Service factor f _B	机型号 Type Type	极数 Pole p	输出转速 Output speed r/min	输出扭矩 Output torque Nm	传动比 Ratio i	使用系数 Service factor f _B	机型号 Type Type	极数 Pole p
4kW						5.5kW					
8.2	4385	175.83	0.92			2.5	18699	576	0.90		
9.2	3919	157.16	1.03			2.9	16329	503	1.04		
10	3528	141.47	1.15			3.2	14479	446	1.17		
11	3195	128.12	1.27			4.1	11460	353	1.48	FA 157R97	4
13	2833	113.61	1.43	FA 97	4	4.8	9771	301	1.73	FAF157R97	4
14	2561	102.72	1.58	FAF97	4	5.3	8830	272	1.92	F 157R97	4
15	2427	97.31	1.67	F 97	4	6.2	7499	231	2.3	FF 157R97	4
16	2263	90.77	1.79	FF 97	4	7.1	6558	202	2.6		
18	2023	81.13	2.0			7.3	6363	196	2.7		
20	1821	73.03	2.2								
22	1649	66.14	2.5			3.5	13537	417	0.83		
						3.9	12109	373	0.93	FA 127R87	4
13	2730	109.49	1.03			4.6	10129	312	1.11	FAF127R87	4
15	2441	97.89	1.16			4.9	9512	293	1.19	F 127R87	4
16	2195	88.01	1.28	FA 87	4	5.5	8505	262	1.33	FF 127R87	4
19	1905	76.39	1.48	FAF87	4	6.4	7337	226	1.54		
21	1706	68.40	1.65	F 87	4						
25	1415	56.75	1.99	FF 87	4	3.4	13732	423	0.82	FA 127R77	4
29	1254	50.29	2.2			3.9	12044	371	0.94	FAF127R77	4
32	1128	45.22	2.5							F 127R77	4
										FF 127R77	4
22	1653	66.28	0.85			2.7	18293	266.76	0.92		
25	1450	58.16	0.97			3.3	14977	218.40	1.1		
26	1374	55.12	1.03			4.0	12149	177.17	1.4		
30	1203	48.24	1.17			4.4	11269	164.33	1.5	FA 157	8
33	1084	43.46	1.30			5.1	9724	141.80	1.7	FAF157	8
38	951	38.12	1.48	FA 77	4	5.8	8581	125.14	2.0	F 157	8
43	839	33.64	1.68	FAF77	4	6.6	7440	108.49	2.3	FF 157	8
48	744	29.82	1.90	F 77	4	7.5	6619	96.53	2.6		
50	717	28.59	1.97	FF 77	4	8.3	5959	86.90	2.8		
56	636	25.50	2.2			9.1	5450	79.47	3.1		
57	635	25.47	2.2			10	4742	69.15	3.6		
67	534	21.43	2.6								
73	491	19.70	2.9			4.2	11817	172.33	0.95	FA 127	8
						4.7	10616	154.81	1.06	FAF127	8
53	683	27.41	1.13			5.7	8620	125.71	1.31	F 127	8
57	627	25.13	1.23			6.2	7555	116.00	1.42	FF 127	8
65	550	22.05	1.40								
69	521	20.90	1.48			6.7	7373	215.04	0.98		
79	456	18.29	1.69			7.2	6834	199.31	1.06	FA 107	4
87	411	16.48	1.88			8.1	6125	178.64	1.18	FAF107	4
100	361	14.46	2.1	FA 67	4	8.9	5530	161.28	1.31	F 107	4
113	318	12.76	2.4	FAF67	4	9.8	5023	146.49	1.44	FF 107	4
127	282	11.31	2.7	F 67	4	11	4456	129.97	1.62		
149	241	9.66	3.2	FF 67	4						
150	240	9.61	2.1			12	4044	117.94	1.79	FA 107	4
158	227	9.11	2.4			14	3476	101.38	2.1	FAF107	4
181	199	7.97	2.9			16	3171	92.47	2.3	F 107	4
201	179	7.18	3.3			16	3034	88.49	2.4	FF 107	4
229	157	6.30	3.6			17	2880	83.99	2.5		
259	139	5.56	4.0								
292	123	4.93	4.3			11	4393	128.12	0.92		
342	105	4.21	4.5			13	3895	113.61	1.04		
						14	3522	102.72	1.15		
68	528	21.17	1.07			15	3336	97.31	1.21		
75	477	19.11	1.18			16	3112	90.77	1.30	FA 97	4
86	419	16.81	1.35			17	2985	87.06	1.35	FAF97	4
91	396	15.88	1.42			18	2782	81.13	1.45	F 97	4
107	337	13.52	1.67			19	2620	76.40	1.54	FF 97	4
117	306	12.29	1.84	FA 57	4	21	2504	73.03	1.68		
135	265	10.64	2.1	FAF57	4	22	2268	66.14	1.78		
155	232	9.31	1.70	F 57	4	25	2011	58.65	2.0		
176	204	8.19	1.93	FF 57	4	27	1818	53.03	2.2		
186	193	7.73	2.0								
219	164	6.58	2.4			16	3018	88.01	0.93	FA 87	4
241	149	5.98	2.6			19	2619	76.39	1.08	FAF87	4
278	129	5.18	3.0			21	2345	68.40	1.20	F 87	4
						25	1946	56.75	1.45	FF 87	4



F

输出转速 Output speed r/min	输出扭矩 Output torque Nm	传动比 Ratio i	使用系数 Service factor f _B	机型号 Type Type	极数 Pole p	输出转速 Output speed r/min	输出扭矩 Output torque Nm	传动比 Ratio i	使用系数 Service factor f _B	机型号 Type Type	极数 Pole p
5.5kW						7.5kW					
29	1724	50.29	1.64			8.4	8023	85.80	2.1		
32	1550	45.22	1.82			9.2	7337	78.46	2.3	FA 157	8
37	1346	39.25	2.1			10.5	6385	68.28	2.7	FAF157	8
41	1205	35.14	2.3	FA 87	4	12	5634	60.25	3.0	F 157	8
49	1000	29.16	2.8	FAF87	4	13.8	4885	52.24	3.5	FF 157	8
42	1170	34.11	2.1	F 87	4	15.5	4346	46.48	3.9		
51	974	28.41	2.4	FF 87	4	18	3746	40.06	4.5		
54	909	26.50	3.1			3.6	18709	266.76	0.90		
61	812	23.68	3.5			4.4	15317	218.40	1.11		
30	1654	48.24	0.85			5.4	12425	177.17	1.36		
33	1490	43.46	0.95			5.8	11525	164.33	1.47		
38	1307	38.12	1.08			6.8	9945	141.80	1.70	FA 157	6
43	1153	33.64	1.22			7.7	8776	125.14	1.93	FAF157	6
48	1022	29.82	1.38	FA 77	4	8.8	7609	108.49	2.2	F 157	6
56	874	25.50	1.61	FAF77	4	9.9	6770	96.53	2.5	FF 157	6
57	873	25.47	1.61	F 77	4	11	6095	86.90	2.8		
67	735	21.43	1.92	FF 77	4	12	5573	79.47	3.0		
73	675	19.70	2.1			14	4850	69.15	3.5		
82	600	17.49	2.4			16	4280	61.02	4.0		
92	536	15.64	2.6			18	3711	52.91	4.6		
102	482	14.06	2.9			5.7	11816	126.36	0.95	FA 127	8
118	418	12.20	3.4			6.2	10776	115.24	1.05	FAF127	8
65	756	22.05	1.02			7.2	9326	99.73	1.21	F 127	8
69	717	20.9	1.08			8.2	8229	88.00	1.37	FF 127	8
79	627	18.29	1.23			5.6	12086	172.33	0.93	FA 127	6
87	565	16.48	1.36			6.2	10857	154.81	1.04	FAF127	6
100	496	14.46	1.50			7.6	8816	125.71	1.28	F 127	6
113	438	12.76	1.55	FA 67	4	8.3	8135	116.00	1.39	FF 127	6
127	388	11.31	1.70	FAF67	4	8.5	7947	172.33	1.42	FA 127	4
149	331	9.66	1.76	F 67	4	9.4	7139	154.81	1.58	FAF127	4
150	329	9.61	2.0	FF 67	4	12	5797	125.71	1.95	F 127	4
158	312	9.11	2.1							FF 127	4
181	273	7.97	2.3			8.2	8238	178.64	0.88		
201	246	7.18	2.4			9.1	7437	161.28	0.97		
229	216	6.30	2.7			10	6755	146.49	1.07		
259	191	5.56	2.9			11	5994	129.97	1.20		
292	169	4.93	3.1			12	5439	117.94	1.33	FA 107	4
342	144	4.21	3.3			14	4675	101.38	1.54	FAF107	4
86	576	16.81	0.98			16	4264	92.47	1.69	F 107	4
91	544	15.88	1.04			16	4081	88.49	1.77	FF 107	4
107	464	13.52	1.22	FA 57	4	17	3873	83.99	1.86		
117	421	12.29	1.34	FAF57	4	20	3436	74.52	2.1		
135	365	10.64	1.55	F 57	4	22	3118	67.62	2.3		
176	281	8.19	1.41	FF 57	4	15	4487	97.31	0.90		
186	265	7.73	1.49			16	4186	90.77	0.97		
219	226	6.58	1.75			17	4015	87.06	1.01		
241	205	5.98	1.93			18	3741	81.13	1.08		
278	178	5.18	2.2			19	3523	76.40	1.15		
7.5kW						7.5kW					
4.6	13812	312	0.82	FA 127R87	4	21	3229	70.03	1.25	FA 97	4
4.9	12971	293	0.87	FAF127R87	4	22	3050	66.14	1.33	FAF97	4
5.5	11598	262	0.97	F 127R87	4	25	2705	58.65	1.49	F 97	4
6.4	10005	226	1.13	FF 127R87	4	28	2445	53.03	1.65	FF 97	4
7.2	8854	200	1.27			32	2072	44.94	1.95		
3.3	20350	217.62	0.83			33	2023	43.87	2.0		
4.0	16664	178.20	1.02			37	1810	39.26	2.2		
4.4	15238	162.96	1.11	FA 157	8	40	1704	36.96	2.4		
5.1	13260	141.80	1.28	FAF157	8	43	1580	34.26	2.6		
5.8	11702	125.14	1.45	F 157	8	44	1514	32.83	2.7		
6.6	10145	108.49	1.67	FF 157	8	48	1416	30.70	2.9		
7.5	9027	96.53	1.87								



输出转速 Output speed r/min	输出扭矩 Output torque Nm	传动比 Ratio i	使用系数 Service factor f _B	机型号 Type Type	极数 Pole p	输出转速 Output speed r/min	输出扭矩 Output torque Nm	传动比 Ratio i	使用系数 Service factor f _B	机型号 Type Type	极数 Pole p
7.5kW						11kW					
26	2617	56.75	1.08			15	6529	96.53	2.6	FA 157	4
29	2319	50.29	1.19			17	5877	86.90	2.9	FAF157	4
32	2085	45.22	1.27			18	5375	79.47	3.1	F 157	4
37	1810	39.25	1.41			21	4677	69.15	3.6	FF 157	4
42	1620	35.14	1.51			7.7	12864	125.71	0.88	FA 127	6
50	1345	29.16	1.75	FA 87	4	8.4	11732	116.00	0.96	FAF127	6
51	1327	28.41	1.74	FAF87	4	10	10153	99.73	1.11	F 127	6
55	1222	26.50	2.3	F 87	4	11	8958	88.00	1.26	FF 127	6
62	1092	23.68	2.6	FF 87	4	13	7737	76.00	1.46		
68	983	21.32	2.9			8.5	11656	172.33	0.97		
76	890	19.31	3.2			9.4	10471	154.81	1.08	FA 127	4
85	789	17.12	3.6			12	8502	125.71	1.33	FAF127	4
94	714	15.48	4.0			13	7846	116.00	1.44	F 127	4
43	1551	33.64	0.91			15	6745	99.73	1.67	FF 127	4
49	1375	29.82	1.03			17	5952	88.00	1.90		
57	1176	25.50	1.16			19	5140	76.00	2.2		
57	1175	25.47	1.20			12	7977	117.94	0.91		
68	988	21.43	1.43			14	6857	101.38	1.05		
74	908	19.70	1.55			16	6254	92.47	1.15		
83	807	17.49	1.75			17	5681	83.99	1.27		
93	721	15.64	1.95	FA 77	4	20	5040	74.52	1.43	FA 107	4
104	648	14.06	2.2	FAF77	4	22	4573	67.62	1.58	FAF107	4
120	563	12.20	2.5	F 77	4	25	3931	58.12	1.84	F 107	4
134	504	10.93	2.8	FF 77	4	29	3431	50.73	2.1	FF 107	4
156	431	9.35	2.4			34	2910	43.03	2.5		
176	383	8.30	2.7			43	2285	33.78	3.2		
197	342	7.42	3.0			53	1855	27.43	3.9		
219	308	6.67	3.3			58	1712	25.31	4.2		
252	267	5.79	3.8			22	4473	66.14	0.90		
281	239	5.19	4.2			25	3967	58.65	1.02		
340	198	4.30	4.8			28	3587	53.03	1.13		
11kW						11kW					
4.9	19275	301	0.88			32	3040	44.94	1.33	FA 97	4
5.4	17418	272	0.97	FA 157R97	4	37	2655	39.26	1.52	FAF97	4
6.3	14793	231	1.14	FAF157R97	4	43	2317	34.26	1.74	F 97	4
7.2	12936	202	1.31	F 157R97	4	44	2220	32.83	1.82	FF 97	4
7.4	12551	196	1.35	FF 157R97	4	48	2076	30.70	1.95		
6.5	14472	226	0.78	FA 127R87	4	53	1875	27.72	2.2		
7.3	12807	200	0.88	FAF127R87	4	58	1703	25.18	2.4		
8.7	10758	168	1.05	F 127R87	4	65	1511	22.34	2.7		
				FF 127R87	4	37	2655	39.25	0.96		
5.1	19181	141.80	0.88	FA 157	8	42	2377	35.14	1.03		
5.8	16928	125.14	1.00	FAF157	8	50	1972	29.16	1.20		
6.7	14675	108.49	1.15	F 157	8	55	1792	26.50	1.57	FA 87	4
7.6	13058	96.53	1.30	FF 157	8	62	1602	23.68	1.76	FAF87	4
5.5	18036	177.17	0.94			68	1442	21.32	1.96	F 87	4
5.9	16729	164.33	1.01			76	1306	19.31	2.16	FF 87	4
6.8	14435	141.80	1.17	FA 157	6	85	1158	17.12	2.4		
7.8	12739	125.14	1.33	FAF157	6	94	1047	15.48	2.7		
8.9	11044	108.49	1.53	F 157	6	111	887	13.12	3.2		
10	9827	96.53	1.72	FF 157	6	74	1332	19.70	1.06		
11	8847	86.90	1.91			83	1183	17.49	1.19		
12	8090	79.47	2.1			93	1058	15.64	1.33		
5.5	18042	266.76	0.94			104	951	14.06	1.48		
6.7	14776	218.46	1.15			120	825	12.20	1.61	FA 77	4
8.2	12053	177.17	1.40	FA 157	4	134	739	10.93	1.71	FAF77	4
8.9	11114	164.33	1.52	FAF157	4	156	632	9.35	1.81	F 77	4
10	9591	141.80	1.76	F 157	4	176	561	8.30	1.91	FF 77	4
12	8464	125.14	2.0	FF 157	4	197	502	7.42	2.0		
13	7338	108.49	2.3			219	451	6.67	2.3		
						252	392	5.79	2.6		
						281	351	5.19	2.9		
						340	291	4.30	3.3		

F



F

输出转速 Output speed r/min	输出扭矩 Output torque Nm	传动比 Ratio i	使用系数 Service factor f _s	机型号 Type Type	极数 Pole p	输出转速 Output speed r/min	输出扭矩 Output torque Nm	传动比 Ratio i	使用系数 Service factor f _s	机型号 Type Type	极数 Pole p
15kW						15kW					
6.3	20172	231	0.84	FA 157R97	4	55	2444	26.50	1.15		
7.2	17639	202	0.96	FAF157R97	4	62	2184	23.68	1.29		
7.4	17115	196	0.99	F 157R97	4	68	1966	21.32	1.43		
				FF 157R97	4	76	1781	19.31	1.58		
6.8	19685	141.80	0.86	FA 157	6	85	1579	17.12	1.79		
7.8	17372	125.14	0.97	FAF157	6	94	1428	15.48	1.84	FA 87	4
8.9	15061	108.49	1.12	F 157	6	111	1210	13.12	1.98	FAF87	4
10	13400	96.53	1.26	FF 157	6	127	1057	11.46	2.1	F 87	4
11	12063	86.90	1.40			152	884	9.58	2.3	FF 87	4
						173	780	8.46	2.5		
6.7	20143	218.40	0.84			195	692	7.50	2.7		
8.2	16340	177.17	1.04			215	625	6.78	2.8		
8.9	15156	164.33	1.12			254	530	5.75	2.8		
10	13078	141.80	1.29	FA 157	4	291	463	5.02	3.1		
12	11542	125.14	1.47	FAF157	4	348	387	4.20	3.5		
13	10006	108.49	1.69	F 157	4	18.5kW					
15	8903	96.53	1.90	FF 157	4	7.3	21607	202	0.78	FA 157R97	4
17	8015	86.90	2.1			7.5	20965	196	0.81	FAF157R97	4
18	7329	79.47	2.3							F 157R97	4
21	6378	69.15	2.7							FF 157R97	4
24	5628	61.02	3.0								
9.7	13844	99.73	0.81	FA 127	6	8.3	20016	177.17	0.85		
11	12216	88.00	0.92	FAF127	6	8.9	18565	164.33	0.91		
13	10550	76.00	1.07	F 127	6	10	16020	141.80	1.06		
14	9803	70.62	1.15	FF 127	6	12	14138	125.14	1.20	FA 157	4
15	8941	64.41	1.26			14	12257	108.49	1.38	FAF157	4
						15	10906	96.53	1.55	F 157	4
12	11594	125.71	0.97	FA 127	4	17	9818	86.90	1.72	FF 157	4
13	10699	116.00	1.05	FAF127	4	18	8978	79.47	1.88		
15	9198	99.73	1.23	F 127	4	21	7812	69.15	2.2		
17	8116	88.00	1.39	FF 127	4	24	6894	61.02	2.5		
19	7009	76.00	1.61			28	5978	52.91	2.8		
21	6513	70.62	1.73								
16	8528	92.47	0.85			13	13105	116.00	0.86		
16	8161	88.49	0.88			15	11267	99.73	1.00		
17	7746	83.99	0.93			17	9942	88.00	1.13	FA 127	4
20	6873	74.52	1.05			19	8586	76.00	1.31	FAF127	4
22	6237	67.62	1.16	FA 107	4	21	7978	70.62	1.41	F 127	4
25	5360	58.12	1.35	FAF107	4	23	7277	64.41	1.55	FF 127	4
29	4679	50.73	1.54	F 107	4	26	6297	55.74	1.79		
34	3969	43.03	1.82	FF 107	4	30	5557	49.19	2.0		
39	3469	37.61	2.1								
43	3116	33.78	2.3			20	8419	74.52	0.86		
46	2933	31.80	2.5			22	7639	67.62	0.94		
53	2530	27.43	2.8			25	6566	58.12	1.10		
58	2334	25.31	3.1			29	5731	50.73	1.26	FA 107	4
67	2007	21.76	3.6			34	4861	43.03	1.49	FAF107	4
						39	4249	37.61	1.70	F 107	4
32	4145	44.94	0.98	FA 97	4	44	3817	33.78	1.89	FF 107	4
37	3621	39.26	1.12	FAF97	4	46	3593	31.80	2.0		
43	3160	34.26	1.28	F 97	4	53	3099	27.43	2.3		
44	3028	32.83	1.33	FF 97	4	58	2859	25.31	2.5		
48	2831	30.70	1.43			68	2458	21.76	2.9		
53	2557	27.72	1.58								
58	2322	25.18	1.74			37	4435	39.26	0.91		
65	2060	22.34	1.96			45	3709	32.83	1.09		
72	1869	20.27	2.2			53	3132	27.72	1.29		
84	1607	17.42	2.5			58	2845	25.18	1.42	FA 97	4
96	1403	15.21	2.9			66	2524	22.34	1.60	FAF97	4
113	1190	12.90	3.4			73	2290	20.27	1.77	F 97	4
129	1040	11.28	3.9			84	1274	17.42	2.35	FF 97	4
						97	1718	15.21	2.77		
						114	1457	12.90	3.17		
						130	1274	11.28	3.17		



输出转速 Output speed r/min	输出扭矩 Output torque Nm	传动比 Ratio i	使用系数 Service factor f _B	机型号 Type Type	极数 Pole p	输出转速 Output speed r/min	输出扭矩 Output torque Nm	传动比 Ratio i	使用系数 Service factor f _B	机型号 Type Type	极数 Pole p
18.5kW						22kW					
69	2409	21.32	1.17			112	1763	13.12	1.27		
76	2182	19.31	1.29			128	1540	11.46	1.43		
86	1934	17.12	1.46			153	1287	9.58	1.58	FA 87	4
95	1749	15.48	1.50			174	1137	8.46	1.60	FAF87	4
112	1482	13.12	1.61			196	1008	7.50	1.70	F 87	4
128	1295	11.46	1.70	FA 87	4	217	911	6.78	1.83	FF 87	4
153	1082	9.58	1.80	FAF87	4	256	773	5.75	1.86		
174	956	8.46	1.88	F 87	4	293	674	5.02	2.1		
196	847	7.50	1.90	FF 87	4	350	564	4.20	2.4		
217	766	6.78	2.0			30kW					
256	650	5.75	2.2			14	19876	108.49	0.85		
296	567	5.02	2.5			15	17685	96.53	0.96		
350	474	4.20	2.9			17	15920	86.90	1.06		
22kW						18	14559	79.47	1.16	FA 157	4
10	19654	96.53	0.86	FA 157	6	21	12669	69.15	1.34	FAF157	4
11	17693	86.90	0.96	FAF157	6	24	11179	61.02	1.51	F 157	4
12	16180	79.47	1.05	F 157	6	28	9693	52.91	1.75	FF 157	4
14	14079	69.15	1.20	FF 157	6	31	8623	47.07	2.0		
10	19051	141.80	0.89			36	7433	40.57	2.3		
12	16813	125.14	1.01			19	13924	76.00	0.81		
14	14576	108.49	1.16			21	12938	70.62	0.87		
15	12969	96.53	1.30			23	11800	64.41	0.96		
17	11675	86.90	1.45	FA 157	4	26	10212	55.74	1.10		
18	10677	79.47	1.58	FAF157	4	30	9012	49.19	1.25	FA 127	4
21	9290	69.15	1.82	F 157	4	35	7783	42.48	1.45	FAF127	4
24	8198	61.02	2.1	FF 157	4	39	6883	37.57	1.58	F 127	4
28	7108	52.91	2.4			47	5786	31.58	1.6	FF 127	4
31	6324	47.07	2.7			54	4961	26.92	1.95		
36	5451	40.57	3.1			58	4672	25.50	2.4		
45	4430	32.97	3.8			59	4536	24.97	2.8		
15	13399	99.73	0.84			68	3948	21.55	2.9		
17	11823	88.00	0.95			77	3483	19.01	3.2		
19	10211	76.00	1.10	FA 127	4	34	7883	43.03	0.92		
21	9488	70.62	1.19	FAF127	4	39	6890	37.61	1.05		
23	8653	64.41	1.30	F 127	4	46	5826	31.80	1.24		
26	7489	55.74	1.51	FF 127	4	54	5025	27.43	1.44	FA 107	4
30	6609	49.19	1.71			58	4637	25.31	1.56	FAF107	4
35	5707	42.48	1.98			68	3987	21.76	1.81	F 107	4
25	7808	58.12	0.92			77	3518	19.20	2.1	FF 107	4
29	6816	50.73	1.06			89	3038	16.58	2.4		
34	5781	43.03	1.25			100	2688	14.67	2.7		
39	5053	37.61	1.43	FA 107	4	119	2259	12.33	2.9		
44	4540	33.78	1.59	FAF107	4	148	1825	9.96	3.3		
46	4272	31.08	1.69	F 107	4	66	4093	22.34	0.99		
54	3685	27.43	1.96	FF 107	4	73	3714	20.27	1.09		
58	3400	25.31	2.1			84	3191	17.42	1.27		
68	2923	21.76	2.5			97	2787	15.21	1.31		
77	2580	19.20	2.8			114	2363	12.90	1.44	FA 97	4
53	3724	27.72	1.09			130	2067	11.28	1.45	FAF97	4
58	3383	25.18	1.19			159	1698	9.27	1.67	F 97	4
66	3001	22.34	1.35	FA 97	4	175	1541	8.41	1.83	FF 97	4
73	2723	20.27	1.48	FAF97	4	203	1325	7.23	1.85		
84	2340	17.42	1.73	F 97	4	233	1156	6.31	1.86		
97	2043	15.21	2.0	FF 97	4	275	980	5.35	2.1		
114	1733	12.90	2.3			314	857	4.68	2.2		
130	1515	11.28	2.7			18.5kW					
69	2864	21.32	0.98	FA 87	4	69	2409	21.32	1.17		
76	2594	19.31	1.09	FAF87	4	76	2182	19.31	1.29		
86	2300	17.12	1.23	F 87	4	86	1934	17.12	1.46		
95	2080	15.48	1.36	FF 87	4	95	1749	15.48	1.50		

F



重泰减速机

ZHONG TAI REDUCER

品质铸就品牌

输出转速 Output speed r/min	输出扭矩 Output torque Nm	传动比 Ratio i	使用系数 Service factor f _B	机型号 Type Type	极数 Pole p	输出转速 Output speed r/min	输出扭矩 Output torque Nm	传动比 Ratio i	使用系数 Service factor f _B	机型号 Type Type	极数 Pole p
37kW						45kW					
17	19503	86.90	0.87			54	7525	27.57	0.98		
19	17835	79.47	0.95			59	6862	25.14	1.07		
21	15519	69.15	1.09			68	5939	21.76	1.24		
24	13694	61.02	1.24	FA 157	4	77	5241	19.2	1.41		
28	11874	52.91	1.42	FAF157	4	89	4525	16.58	1.63	FA 107	4
31	10564	47.07	1.60	F 157	4	101	4004	14.67	1.80	FAF107	4
36	9105	40.57	1.86	FF 157	4	120	3365	12.33	1.90	F 107	4
45	7399	32.97	2.3			149	2719	9.96	2.0	FF 107	4
53	6275	27.96	2.7			153	2634	9.65	2.1		
						177	2276	8.34	2.2		
						201	2012	7.37	2.3		
						239	1692	6.20	2.6		
15	22261	99.19	0.51			55kW					
27	12509	55.74	0.90			24	20357	61.02	0.83		
35	9534	42.48	1.18			28	17651	52.91	0.96		
39	8432	37.57	1.31			31	15703	47.07	1.08	FA 157	4
47	7087	31.58	1.34			36	13534	40.57	1.25	FAF157	4
58	5723	25.50	1.44			45	10999	32.97	1.54	F 157	4
55	6077	26.92	1.59	FA 127	4	53	9328	27.96	1.66	FF 157	4
60	5557	24.97	1.97	FAF127	4	58	8484	25.43	1.81		
69	4836	21.55	2.3	F 127	4	67	7393	22.16	2.3		
78	4266	19.01	2.4	FF 127	4	75	6595	19.77	2.4		
90	3699	16.48	2.8			88	5621	16.85	3.0		
101	3292	14.67	3.1								
117	2837	12.64	3.2			39	12534	37.57	0.90		
144	2305	10.27	3.3			47	10535	31.58	1.07		
169	1966	8.76	3.3			58	8507	25.5	1.33		
190	1748	7.79	3.9			69	7189	21.55	1.57		
						78	6342	19.01	1.63		
54	6156	27.43	1.20			90	5498	16.48	1.88	FA 127	4
58	5680	25.31	1.30			101	4894	14.67	2.1	FAF127	4
68	4883	21.76	1.51			117	4217	12.64	2.2	F 127	4
77	4309	19.20	1.7			144	3426	10.27	2.3	FF 127	4
89	3721	16.58	2.0	FA 107	4	169	2922	8.76	2.4		
101	3292	14.67	2.1	FAF107	4	190	2599	7.79	2.6		
120	2767	12.33	2.2	F 107	4	220	2242	6.72	2.9		
149	2235	9.96	2.3	FF 107	4	271	1821	5.46	3.1		
153	2166	9.65	2.4			320	1545	4.63	3.7		
177	1872	8.34	2.6								
201	1654	7.37	2.7			75kW					
239	1391	6.20	3.1			31	21413	47.07	0.79		
						36	18456	40.57	0.92		
						45	14999	32.97	1.13		
						53	12719	27.96	1.22	FA 157	4
						58	11569	25.43	1.33	FAF157	4
						67	10081	22.16	1.68	F 157	4
						75	8994	19.77	1.78	FF 157	4
						88	7665	16.85	2.2		
						106	6351	13.96	2.5		
						124	5423	11.92	2.8		
						58	11600	25.50	0.97		
						69	9803	21.55	1.2		
						78	8648	19.01	1.2		
						90	7497	16.48	1.4		
						101	6674	14.67	1.5	FA 127	4
						117	5750	12.64	1.6	FAF127	4
						144	4672	10.27	1.6	F 127	4
						169	3985	8.76	1.7	FF 127	4
						190	3544	7.79	1.9		
						220	3057	6.72	2.2		
						271	2484	5.46	2.3		
						320	2106	4.63	2.7		
45kW											
21	18874	69.15	0.90								
24	16655	61.02	1.02								
28	14442	52.91	1.17	FA 157	4						
31	12848	47.07	1.32	FAF157	4						
36	11074	40.57	1.53	F 157	4						
45	8999	32.97	1.88	FF 157	4						
53	7632	27.96	2.2								
30	13426	49.19	0.84								
35	11595	42.48	0.97								
39	10255	37.57	1.08								
47	8620	31.58	1.10								
55	7391	26.92	1.18								
58	6960	25.50	1.31								
60	6758	24.97	1.62	FA 127	4						
69	5882	21.55	1.92	FAF127	4						
78	5189	19.01	2.0	F 127	4						
90	4498	16.48	2.3	FF 127	4						
101	4004	14.67	2.6								
117	3450	12.64	2.7								
144	2803	10.27	2.8								
169	2391	8.76	2.9								
190	2126	7.79	3.2								
220	1834	6.72	3.6								
271	1490	5.46	3.8								

F



输出转速 Output speed r/min	输出扭矩 Output torque Nm	传动比 Ratio i	使用系数 Service factor f_B	机型号 Type Type	极数 Pole p	输出转速 Output speed r/min	输出扭矩 Output torque Nm	传动比 Ratio i	使用系数 Service factor f_B	机型号 Type Type	极数 Pole p
90kW											
45	17998	32.97	0.94								
53	15263	27.96	1.02								
58	13882	25.43	1.11	FA 157	4						
67	12097	22.16	1.40	FAF157	4						
75	10792	19.77	1.48	F 157	4						
88	9198	16.85	1.84	FF 157	4						
106	7621	13.96	2.1								
124	6507	11.92	2.3								
90kW											
58	13920	25.50	0.81								
69	11764	21.55	0.96								
78	10378	19.01	1.00								
90	8953	16.48	1.15								
101	8008	14.67	1.29	FA 127	4						
117	6900	12.64	1.33	FAF127	4						
144	5606	10.27	1.36	F 127	4						
169	4782	8.76	1.59	FF 127	4						
190	4253	7.79	1.60								
220	3668	6.72	1.79								
271	2981	5.46	1.89								
320	2528	4.63	2.2								
110kW											
53	18530	27.96	0.91								
67	14686	22.16	1.15	FA 157	4						
75	13102	19.77	1.22	FAF157	4						
88	11167	16.85	1.52	F 157	4						
107	9252	13.96	1.73	FF 157	4						
125	7900	11.92	1.90								
132kW											
67	17623	22.16	0.96	FA 157	4						
75	15723	19.77	1.02	FAF157	4						
88	13400	16.85	1.26	F 157	4						
107	11102	13.96	1.44	FF 157	4						
125	9480	11.92	1.59								
160kW											
88	16243	16.85	1.04	FA 157	4						
107	13457	13.96	1.19	FAF157	4						
125	11491	11.92	1.31	F 157	4						
200kW											
88	20304	16.85	0.83	FA 157	4						
107	16821	13.96	0.95	FAF157	4						
125	14363	11.92	1.05	F 157	4						
200kW											
88	20304	16.85	0.83	FA 157	4						
107	16821	13.96	0.95	FAF157	4						
125	14363	11.92	1.05	F 157	4						



Mamax Permissible torque Nm	输出转速 Output speed r/min	传动比 Ratio i	机型号 Type Type	功率 Power kW/4p	Mamax Permissible torque Nm	输出转速 Output speed r/min	传动比 Ratio i	机型号 Type Type	功率 Power kW/4p
200	5.3	262	FA 37R17 FAF37R17 F 37R17 FF 37R17	0.18	1500	2.3	600	FA 77R37 FAF77R37 F 77R37 FF 77R37	0.55
	6.1	229				2.6	525		
	7.0	200		3.0		469	0.75		
	8.2	170		3.4		412			
	9.1	153		3.9		357			
	10	133		4.4		314			
11	129								
400	2.5	563	FA 47R17 FAF47R17 F 47R17 FF 47R17	0.18	3000	0.33	4245	FA 87R57 FAF87R57 F 87R57 FF 87R57	0.18
	2.9	477				0.37	3721		
	3.1	445				0.43	3244		
	3.6	389				0.48	2881		
	4.0	346		0.54		2575	0.25		
	4.6	304		0.63		2199			
	4.7	293		0.72		1930	0.37		
	6.0	230		0.81		1709			
	6.4	216		0.93		1493			
	7.4	188		1.1		1300			
7.9	176	1.2	1148	0.55					
9.4	148	1.4	1010						
11	130	1.6	887						
600	1.6	856	FA 57R37 FAF57R37 F 57R37 FF 57R37	0.18	4300	1.8	780	FA 97R57 FAF97R57 F 97R57 FF 97R57	0.75
	1.9	749				2.1	674		
	2.1	658				2.3	609		
	2.5	549		2.7		515	1.1		
	2.9	483		3.1		452			
	3.3	426		4.0		345	1.5		
	3.6	382		0.21		6532			
	4.2	330		0.24		5696			
	4.7	298		0.28		5032			
	5.3	262		0.32		4375	0.18		
	6.2	226		0.35		3946			
	7.0	200		0.41		3404			
	8.4	166		0.47		2949	0.25		
	9.1	152		0.54		2590			
10	134	0.61	2267	0.37					
		0.70	1989						
820	1.2	1126	FA 67R37 FAF67R37 F 67R37 FF 67R37	0.18	7840	0.80	1739	FA 107R77 FAF107R77 F 107R77 FF 107R77	0.55
	1.4	984				0.90	1542		
	1.6	864				1.0	1340		
	1.9	722		1.2		1182	0.75		
	2.2	633		1.3		1032			
	2.6	527		1.5		907	1.1		
	2.8	500		1.8		796			
	3.1	454		2.0		700			
	3.5	392		2.3		611			
	4.2	333		2.6		534	1.5		
4.7	297	3.0	472						
5.3	261	3.5	410	2.2					
5.8	238	3.9	367						
7.0	200	4.9	288	3					
		5.7	247						
1500	0.7	2024	FA 77R37 FAF77R37 F 77R37 FF 77R37	0.18	7840	0.12	11347	FA 107R77 FAF107R77 F 107R77 FF 107R77	0.18
	0.81	1728				0.14	10039		
	0.91	1543		0.16		8548	0.25		
	1.03	1354		0.18		7675			
	1.2	1196		0.21		6615	0.37		
	1.3	1050		0.24		5820			
	1.5	907		0.27		5223			
1.7	810								
2.0	710								

表上所配功率均有超载,按实际条件确定的转扭不得大于减速机额定转扭。 The power are all overload in the table. The decided torque according to operating condition should not more than gear unit's nominal torque.



Mamax Permissible torque Nm	输出转速 Output speed r/min	传动比 Ratio i	机型号 Type Type	功率 Power kW/4p	Mamax Permissible torque Nm	输出转速 Output speed r/min	传动比 Ratio i	机型号 Type Type	功率 Power kW/4p
7840	0.30	4567	FA 107R77 FAF107R77 F 107R77 FF 107R77	0.37	18000	0.04	31434	FA 157R97 FAF157R97 F 157R97 FF 157R97	0.55
	0.40	3442				0.05	26173		
	0.46	3037		0.06		23464			
	0.50	2756		0.07		20212			
	0.59	2369		0.08		17984			
	0.67	2068		0.09		16358			
	0.76	1826		0.10		13751			
	0.88	1597		0.11		12235			
	1.0	1401		0.20		7065			
	1.1	1243		0.22		6286			
	1.3	1087		0.26		5404			
	1.5	950		0.14		10033			
	1.7	834		0.16		9021			
	1.9	736		0.17		8026			
	2.3	627		0.29		4831			
	2.5	560		0.34		4124			
	2.9	489		0.50		2776			
	3.3	427		0.57		2427			
4.0	362	0.64	2185						
4.3	333	0.39	3602	18000	0.44	3205	FA 157R97 FAF157R97 F 157R97 FF 157R97	2.2	
12000	0.08	16787	0.73		1944				
	0.09	14838	0.85		1674				
	0.11	13014	1.00		1420				
	0.12	11748	1.1		1308				
	0.14	10271	1.2		1169				
	0.16	8901	1.5		953				
	0.18	7703	1.7		845				
	0.21	6768	1.9		764				
	0.23	5975	2.1		680				
	0.27	5076	2.5		576				
	0.31	4466	2.9		503				
	0.36	3868	3.3		446				
	0.41	3403	4.9		301				
	0.47	2987	5.4		272				
	0.52	2693	6.3		231				
	0.59	2376	7.2		202				
	0.68	2054	4.9		196				
	0.78	1798	0.18						
0.86	1619	0.25							
1.0	1401	0.37							
1.2	1230	0.55							
1.3	1085	0.75							
1.5	937	1.1							
1.7	827	1.5							
1.9	733	2.2							
2.2	640	3							
2.7	542	4							
2.9	489	5.5							
3.4	423	7.5							
3.9	371	11							
3.0	483								
3.5	417								
3.9	373								
4.7	312								
5.0	293								
7.3	200								

F

表上所配功率均有超载,按实际条件确定的转扭不得大于减速机额定转扭。 The power are all overload in the table. The decided torque according to operating condition should not more than gear unit's nominal torque.



F

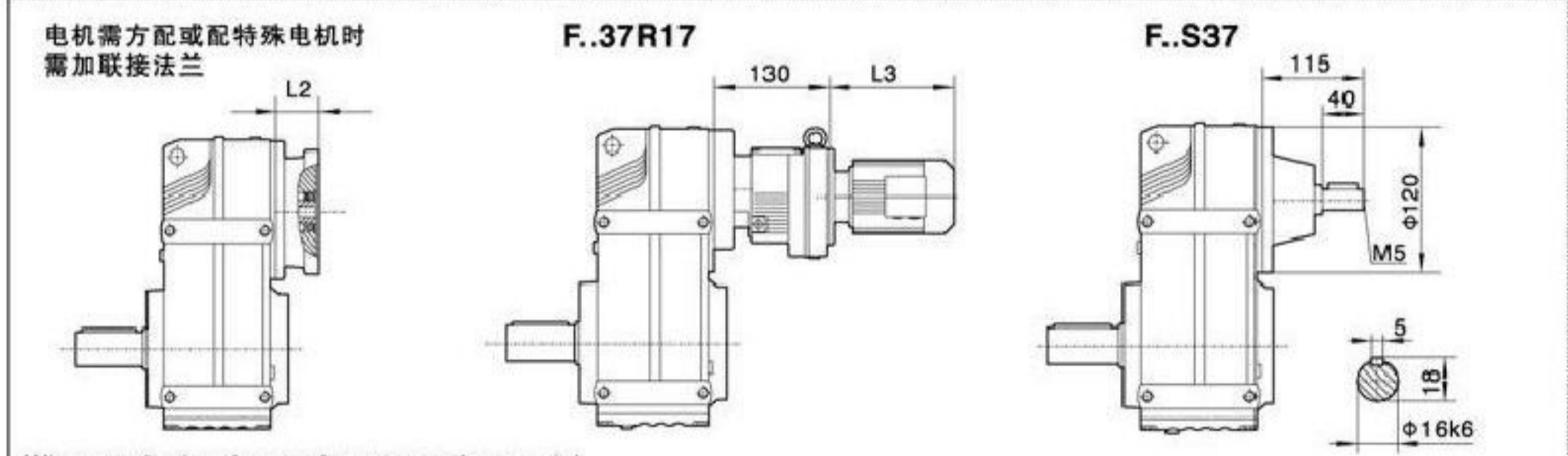
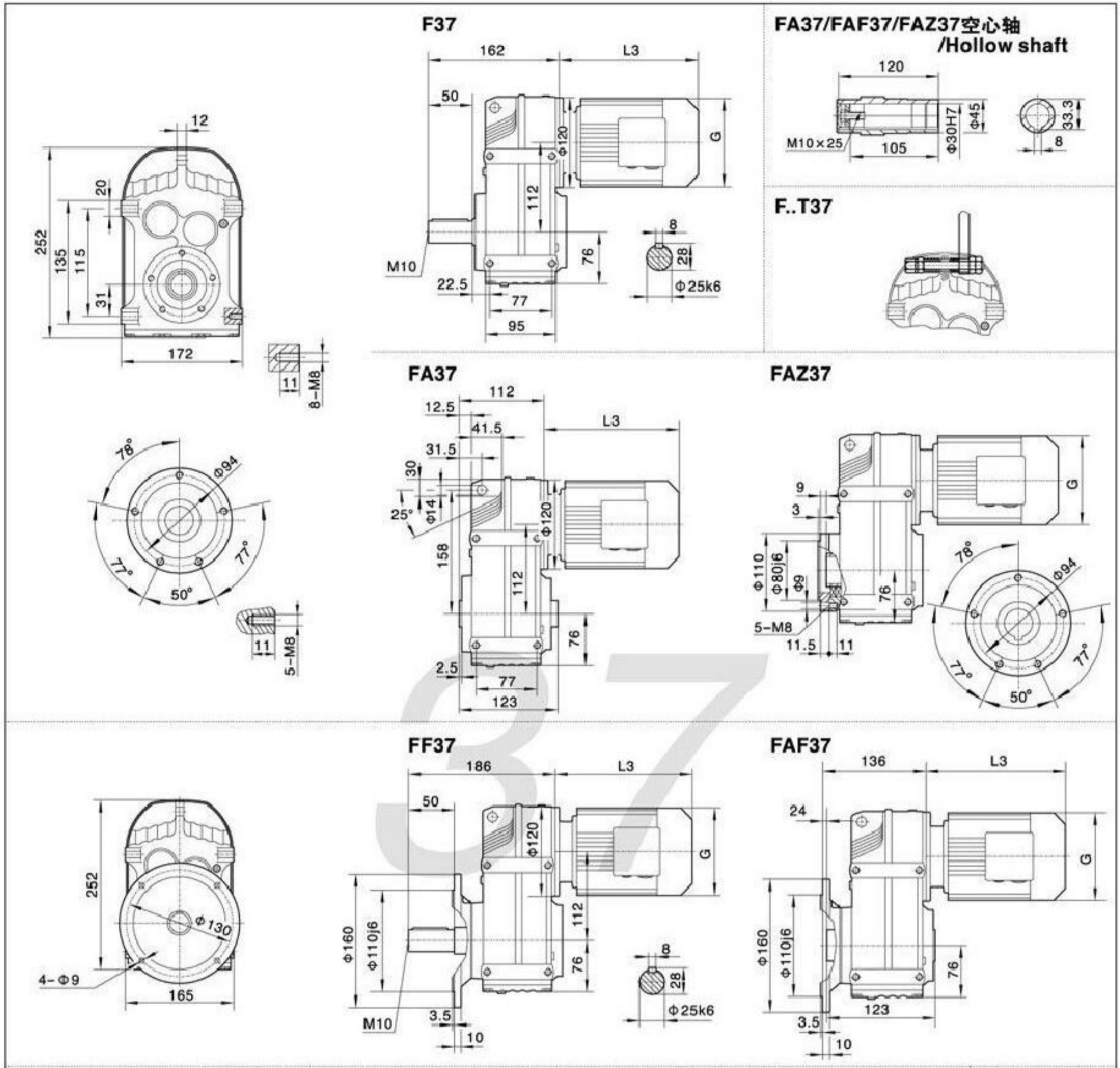

注：其余尺寸见相对应结构形式
Note: For other values please refer to the opposite structure.

When equipping the user's motor or the special one, the flange is required to connected.

Y ₂ 电机座号 Motor size	63	71	80	90S	90L	100
功率/4P Power/(kW)	0.18	0.25 0.37	0.55 0.75	1.1	1.5	2.2 3
L3	235	245	278	304	328	340
G	130	145	175	195	195	215
L2	71	71	71	71	71	93

注:1.以上壳体为通用件,安装尺寸均可相互参照 2."F."表示F、FA、FF、FAF、FAZ



重泰减速机

ZHONG TAI REDUCER

品质铸就品牌

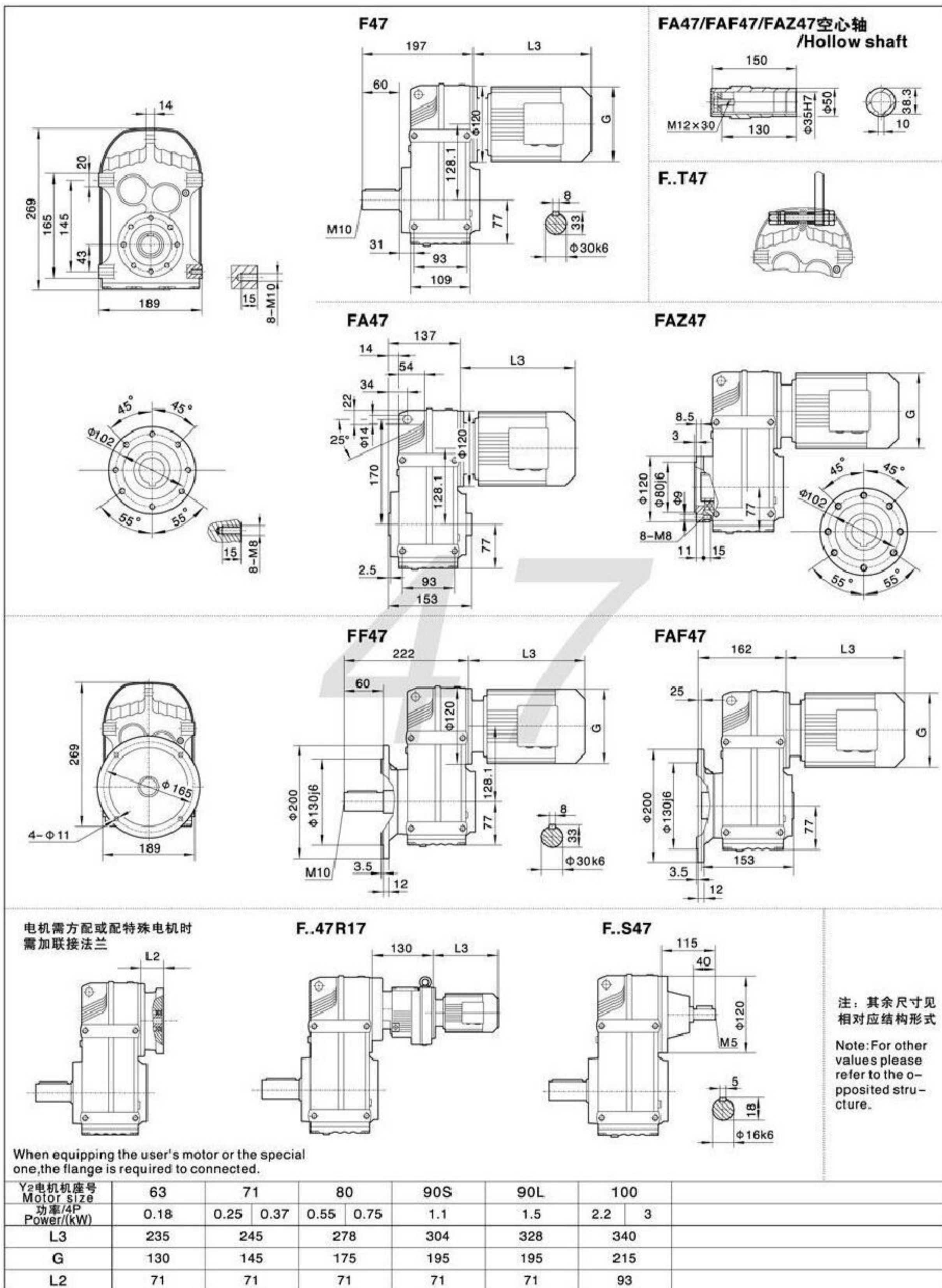

注:1.以上壳体为通用件,安装尺寸均可相互参照 2."F.."表示F, FA, FF, FAF, FAZ

F

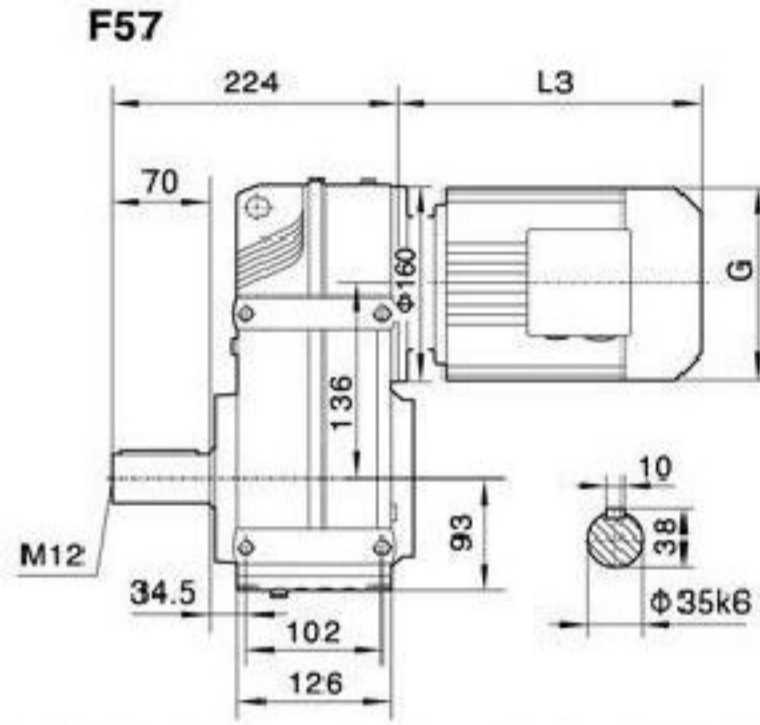
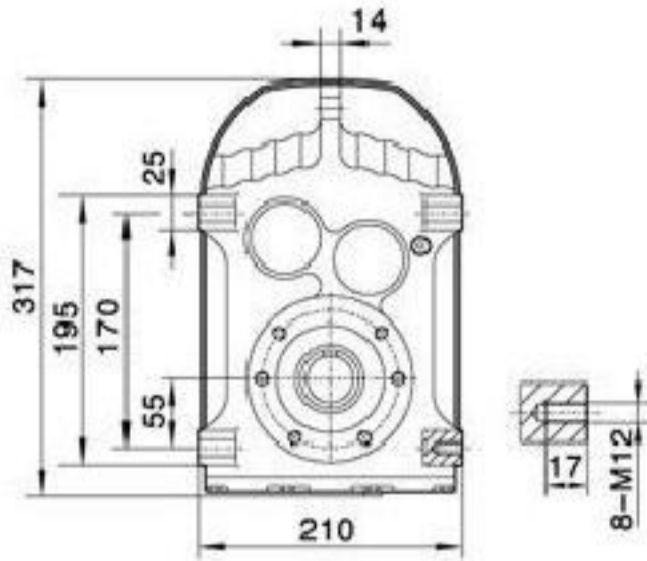

**FA57/FAF57/FAZ57空心轴
/Hollow shaft**

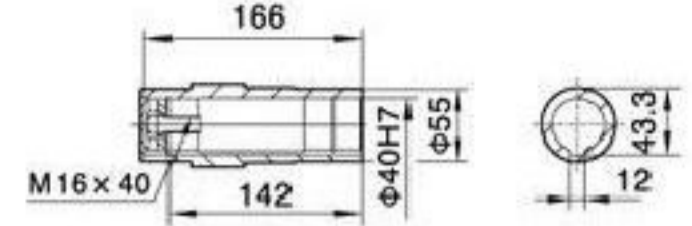

F..T57

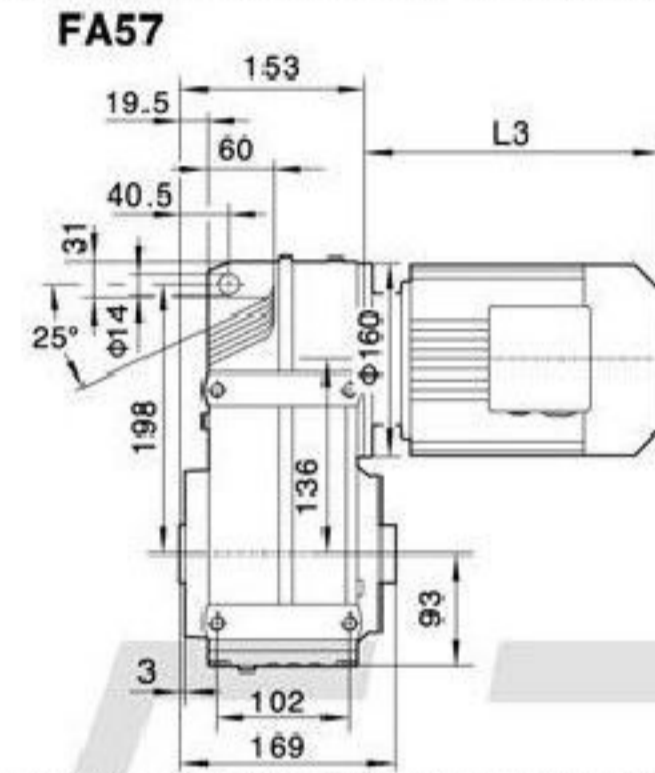
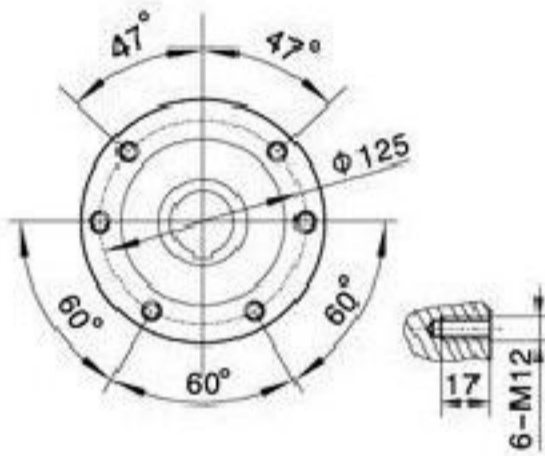

FAZ57

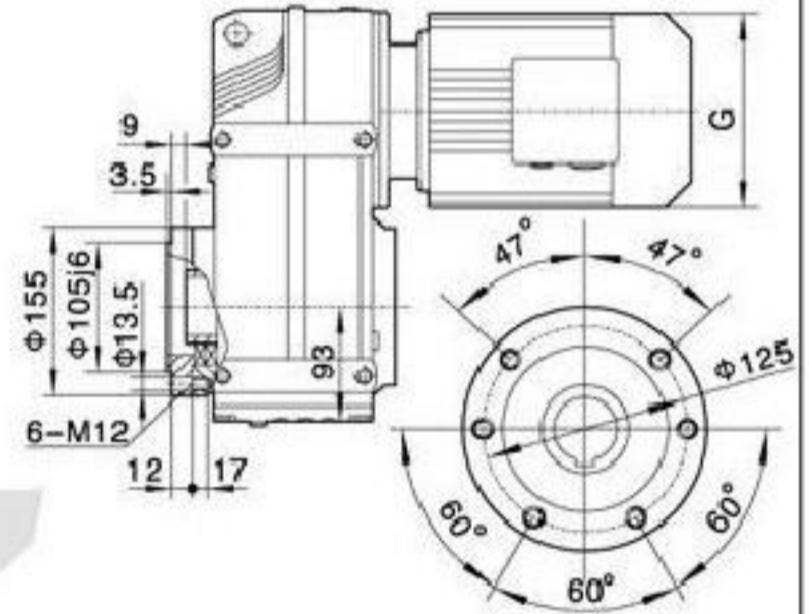

F

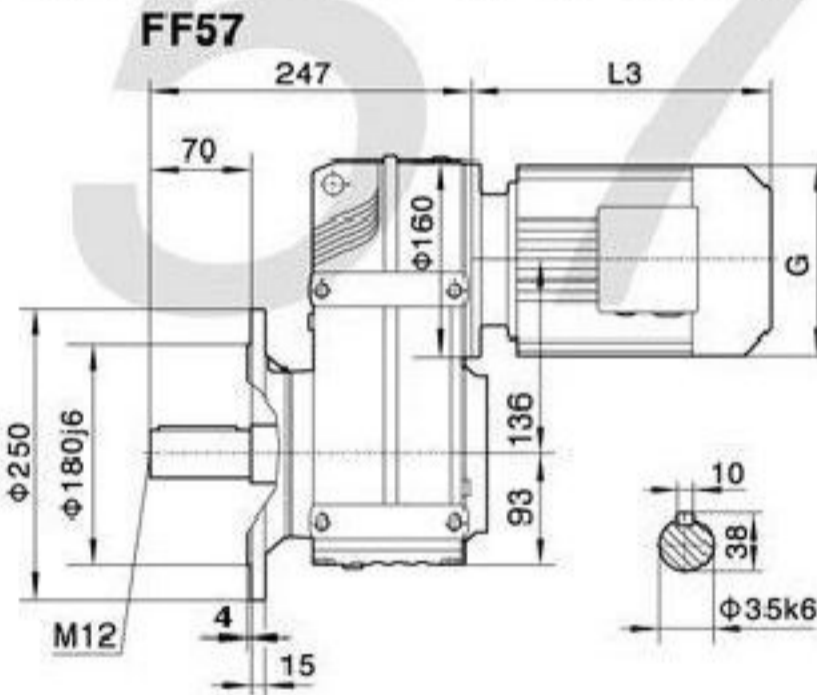
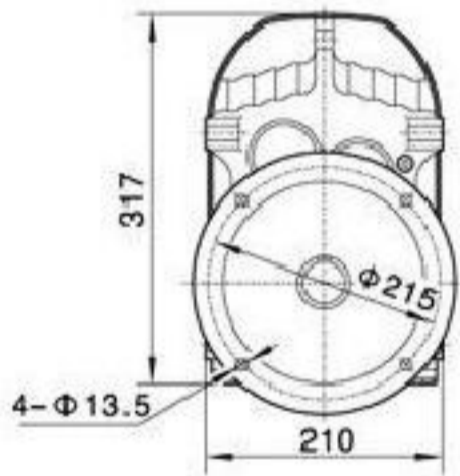

FAF57

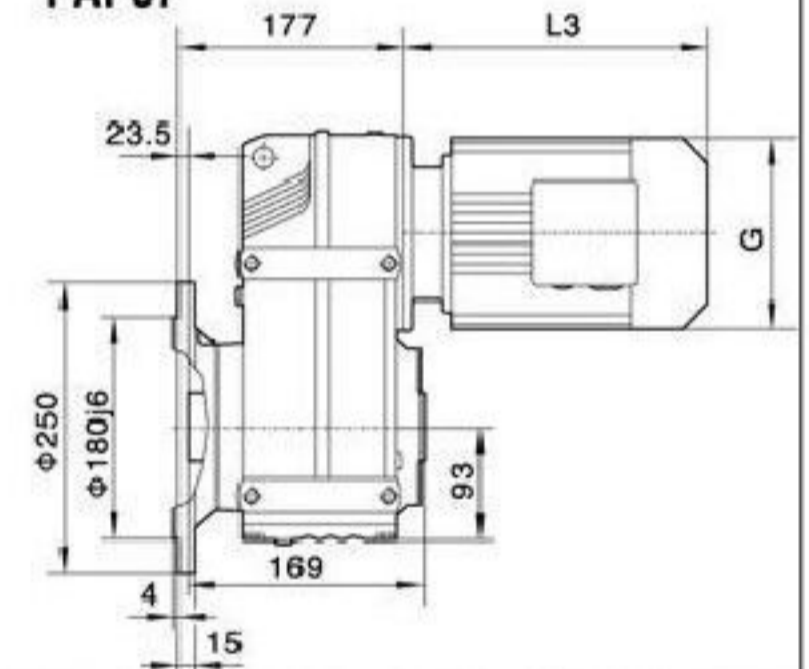

电机需方配或配特殊电机时
需加联接法兰

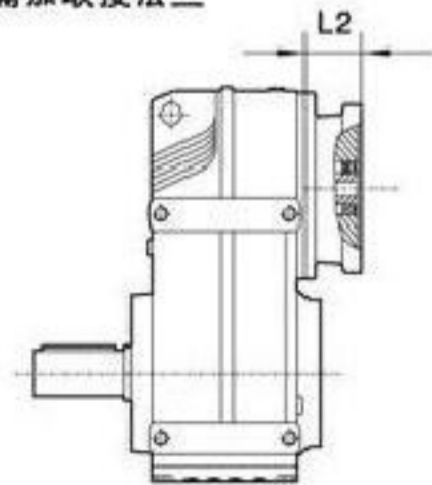

F.57R37

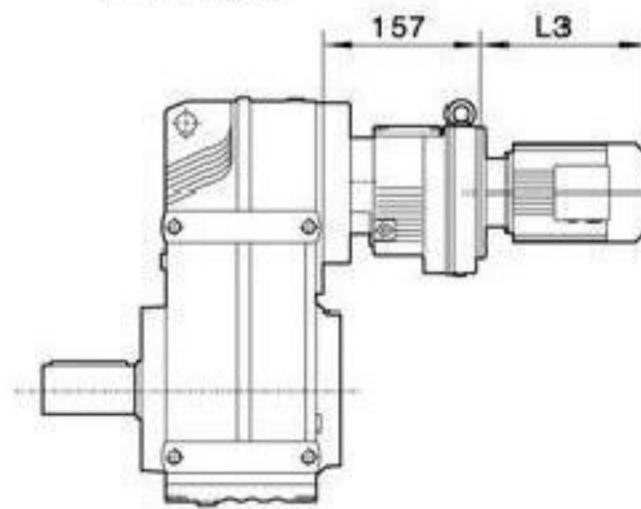

F..S57

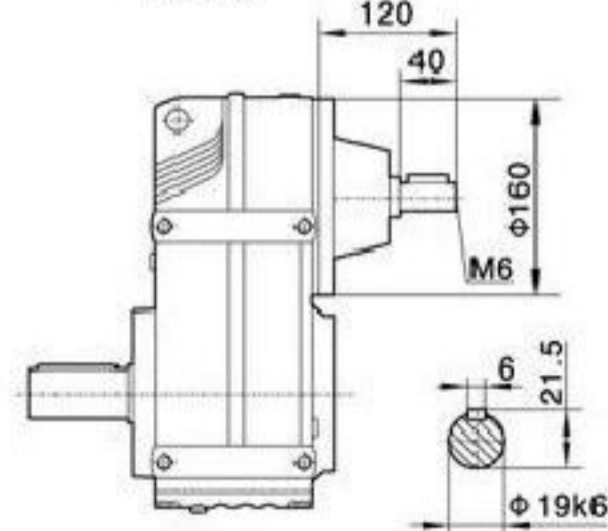

注：其余尺寸见
相对应结构形式

Note: For other
values please
refer to the o-
pposited stru-
cture.

When equipping the user's motor or the special
one, the flange is required to connected.

Y2电机机座号 Motor size 功率/4P Power/(kW)	63	71	80	90S	90L	100	112M	132S
	0.18	0.25 0.37	0.55 0.75	1.1	1.5	2.2 3	4	5.5
L3	223	245	278	304	328	350	380	425
G	130	145	175	195	195	215	240	275
L2	81	81	81	81	81	93	93	101

注:1.以上壳体为通用件,安装尺寸均可相互参照 2."F.."表示F、FA、FF、FAF、FAZ

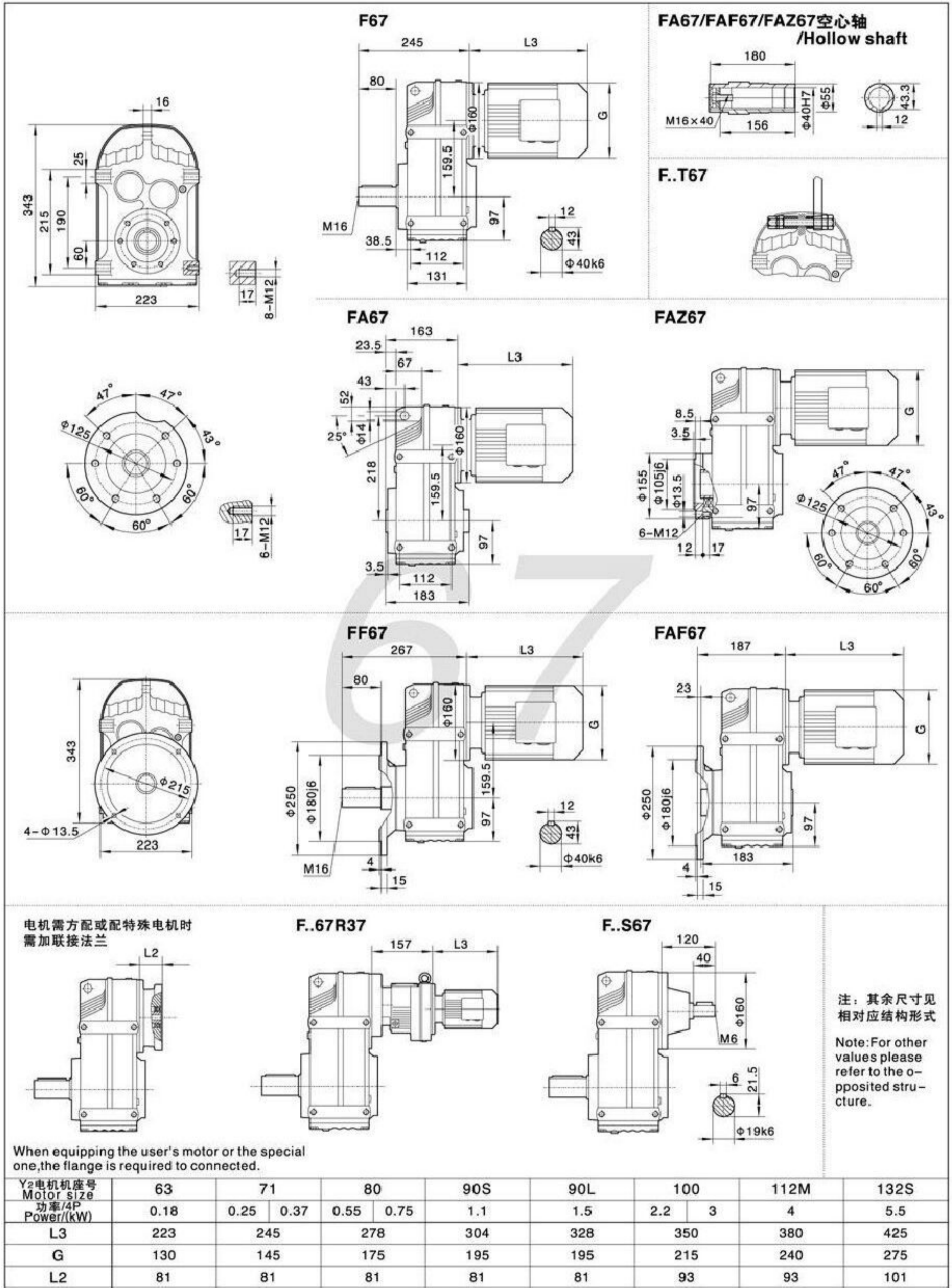

注:1.以上壳体为通用件,安装尺寸均可相互参照 2."F.."表示F, FA, FF, FAF, FAZ



重泰减速机

ZHONG TAI REDUCER

品质铸就品牌

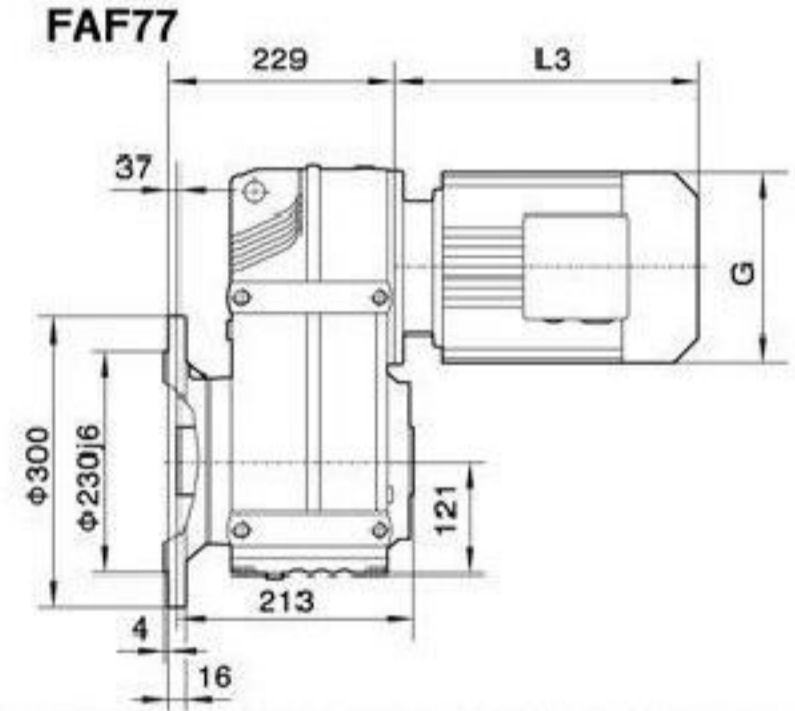
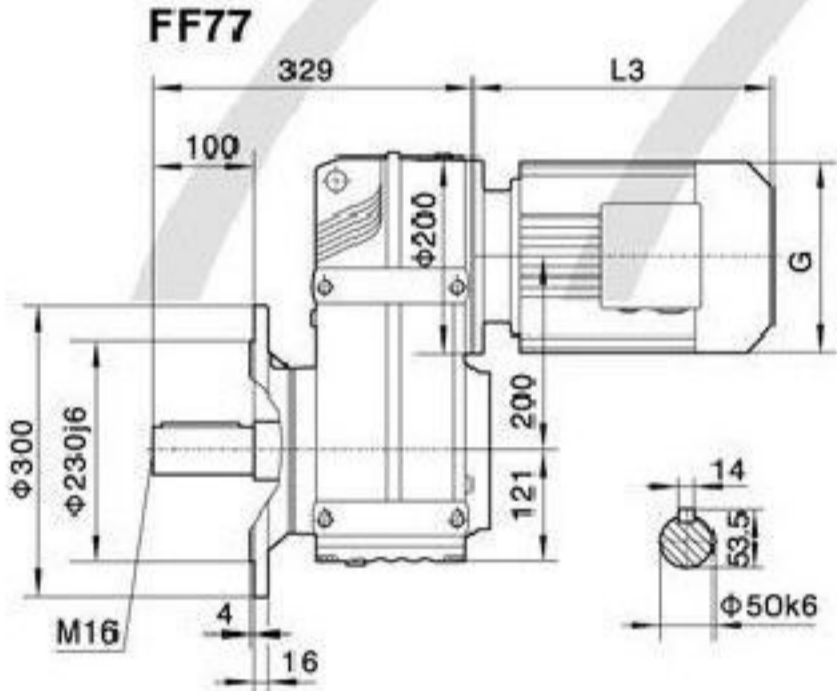
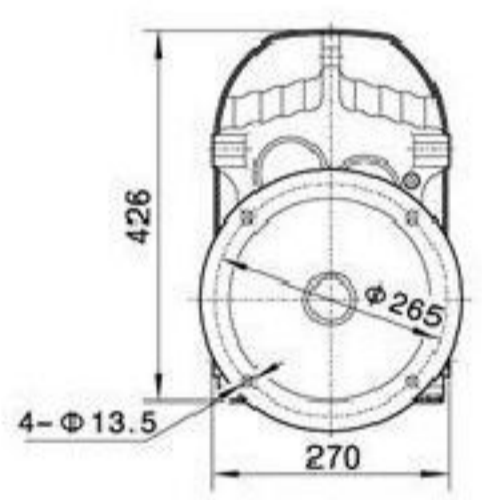
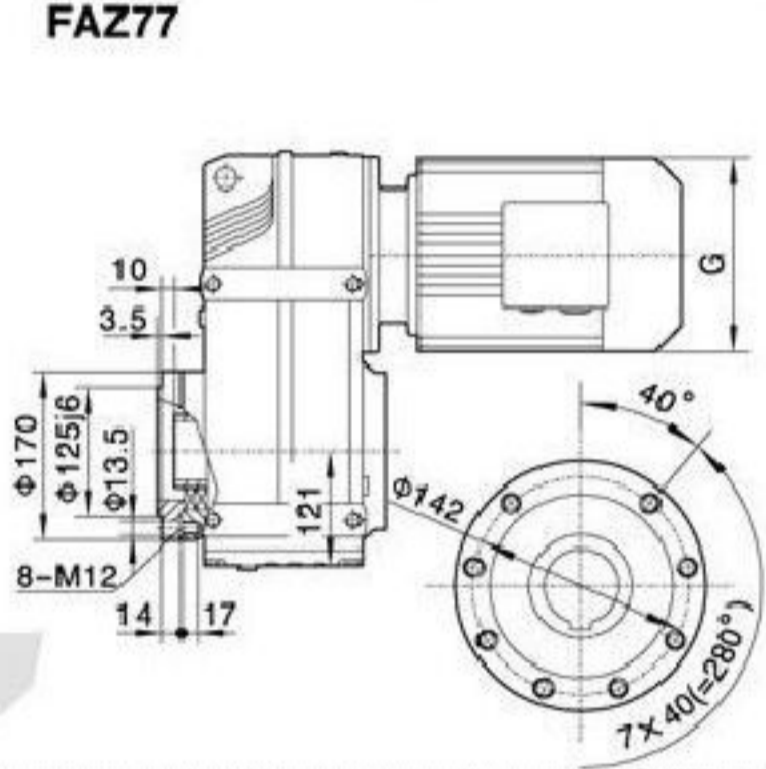
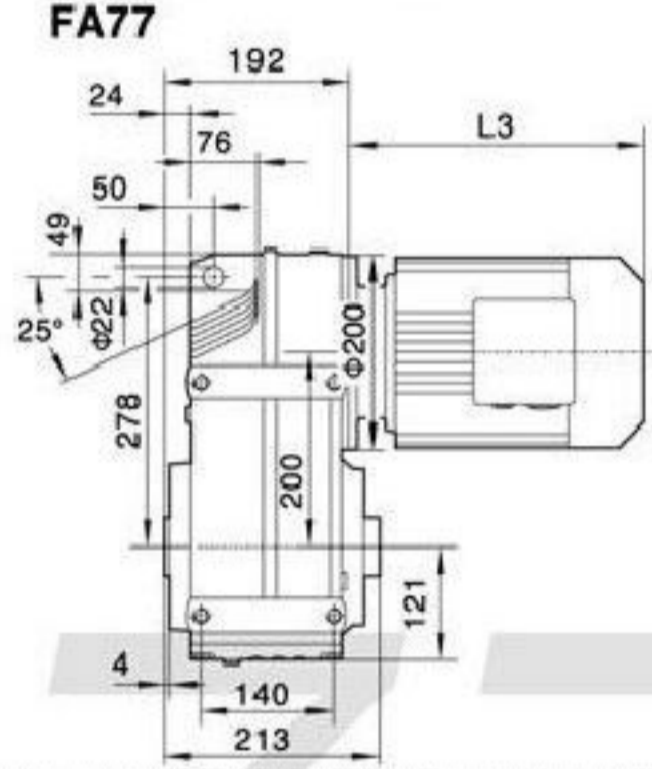
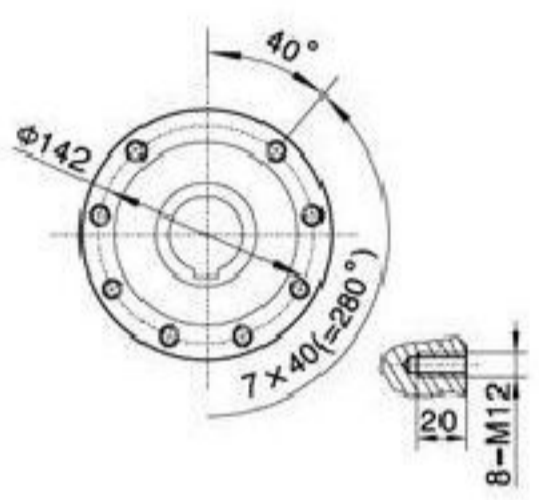
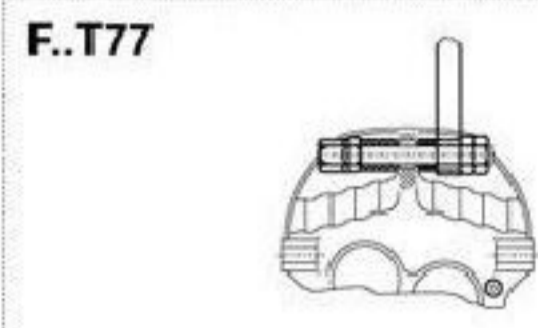
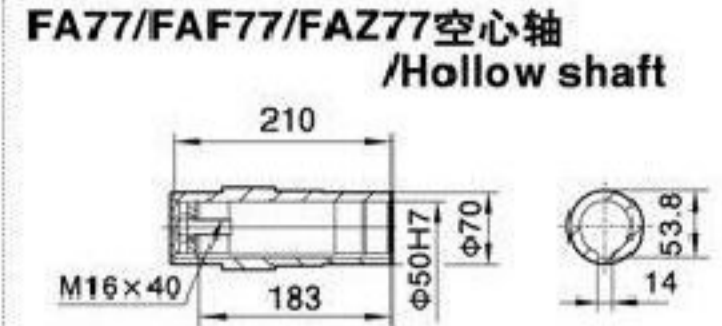
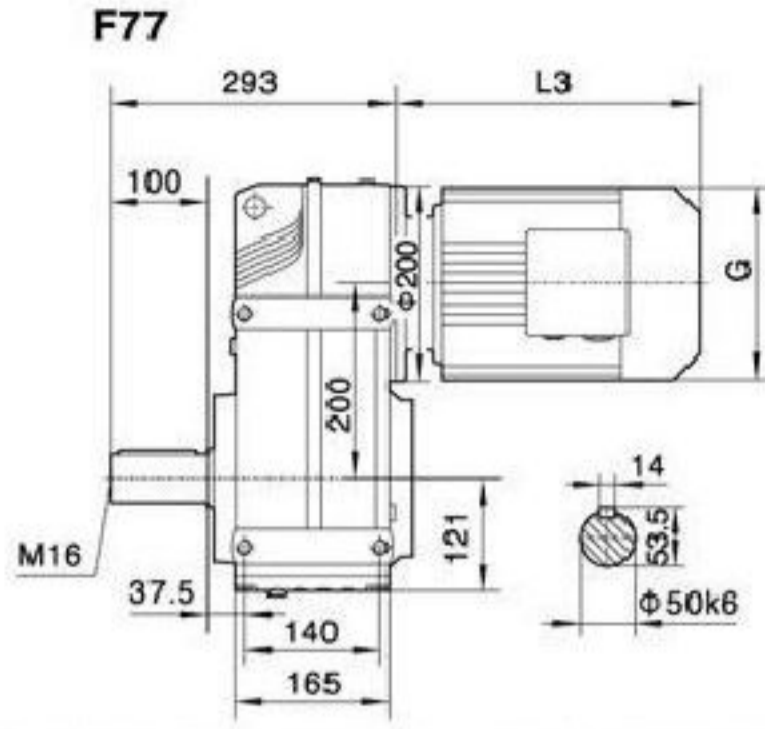
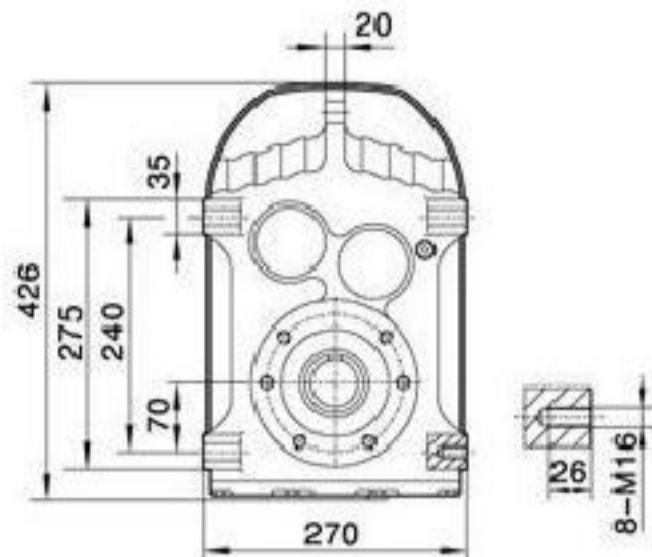

电机需方配或配特殊电机时需加联接法兰

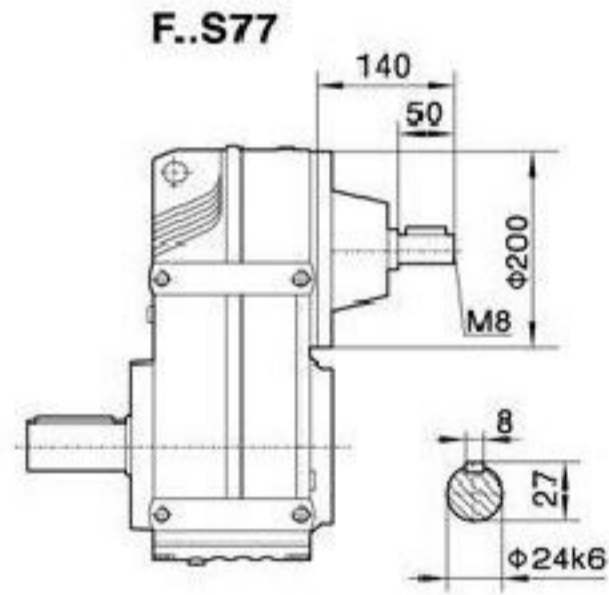
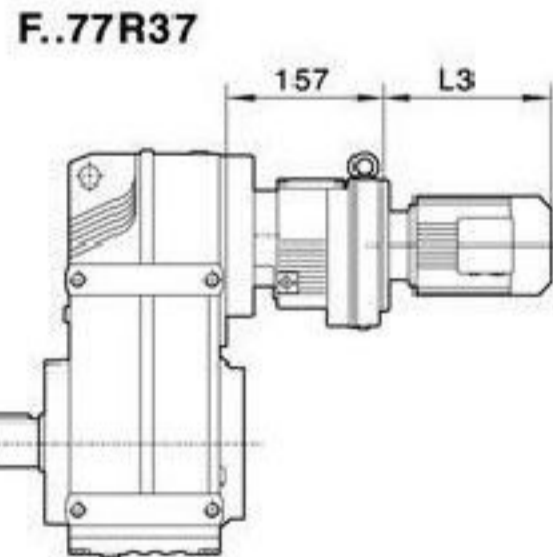
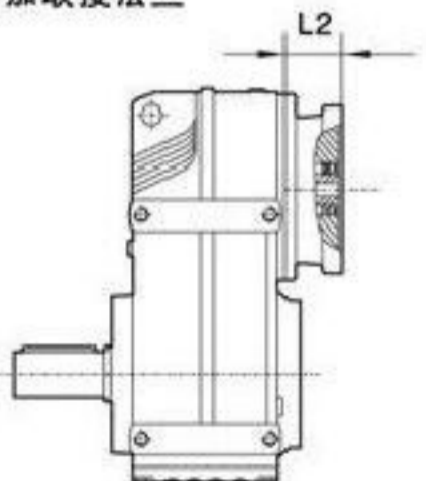

注: 其余尺寸见相对应结构形式
Note: For other values please refer to the opposite structure.

When equipping the user's motor or the special one, the flange is required to connected.

Y2电机机座号 Motor size	71	80	90S	90L	100	112M	132S	132M	160M
功率/4P Power/(kW)	0.37	0.55 0.75	1.1	1.5	2.2 3	4	5.5	7.5	11
L3	233	278	304	328	350	380	425	461	524
G	145	175	195	195	215	240	275	275	330
L2	81	81	81	81	93	93	101	101	126

注: 1. 以上壳体为通用件, 安装尺寸均可相互参照 2. "F.."表示F, FA, FF, FAF, FAZ

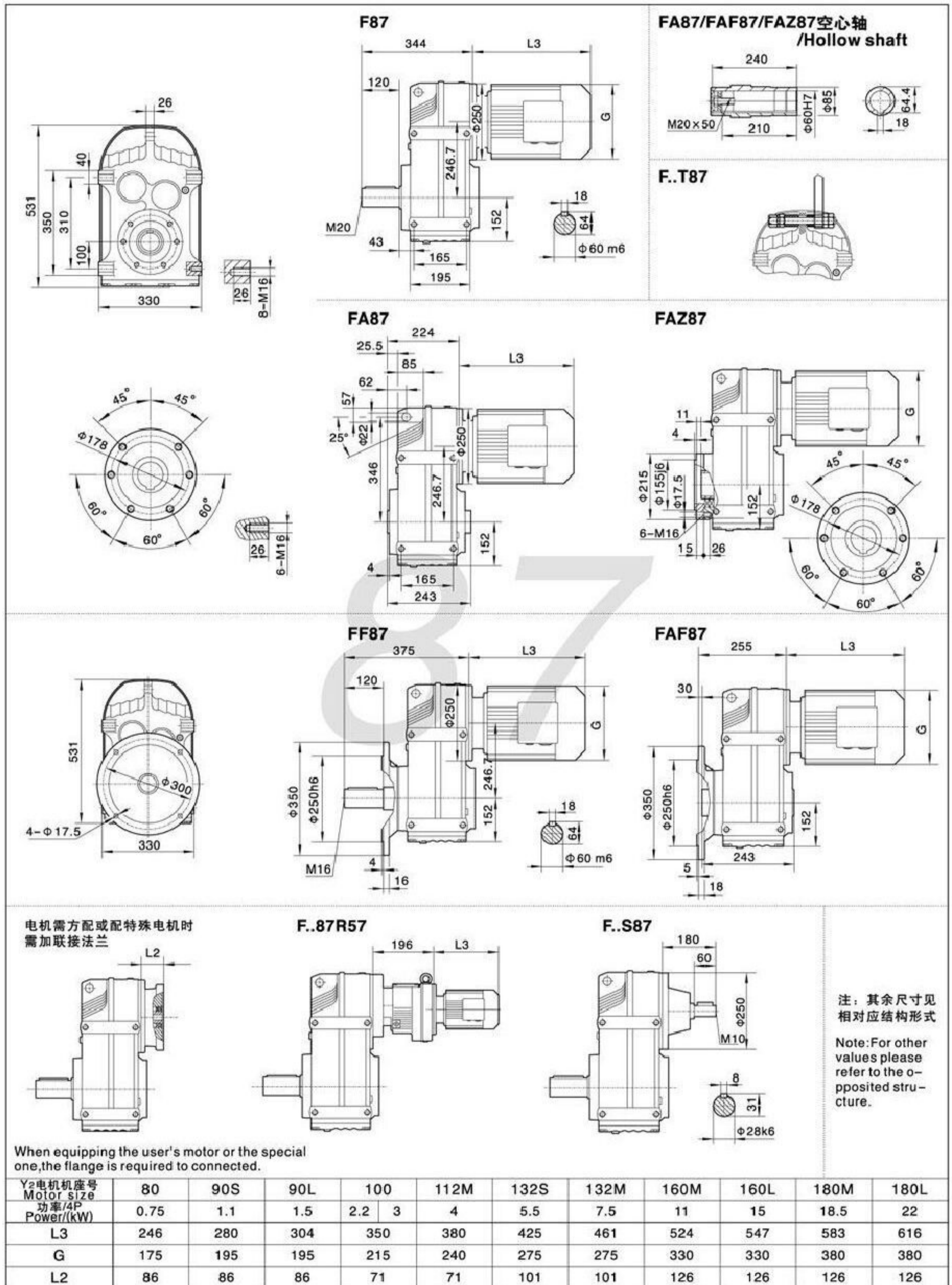

F

注:1.以上壳体为通用件,安装尺寸均可相互参照 2."F."表示F, FA, FF, FAF, FAZ



重泰减速机

ZHONG TAI REDUCER

品质铸就品牌

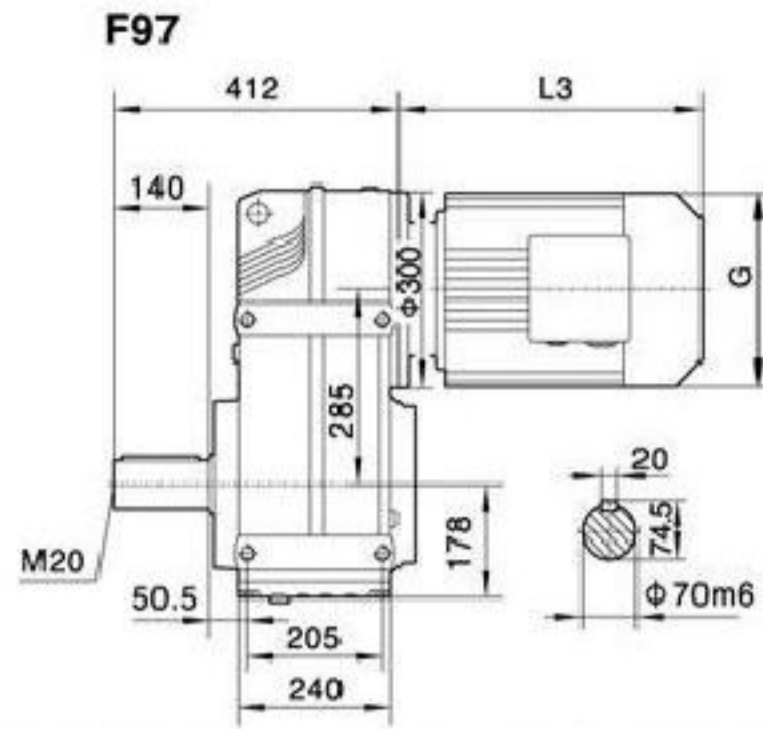
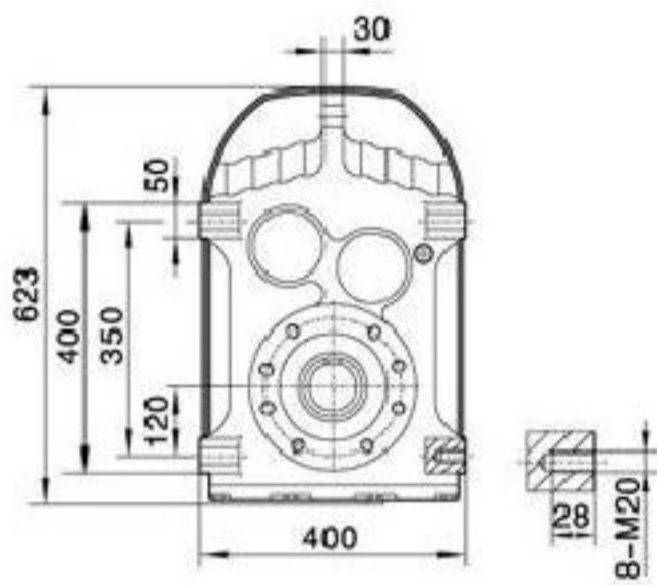

FA97/FAF97/FAZ97空心轴 /Hollow shaft

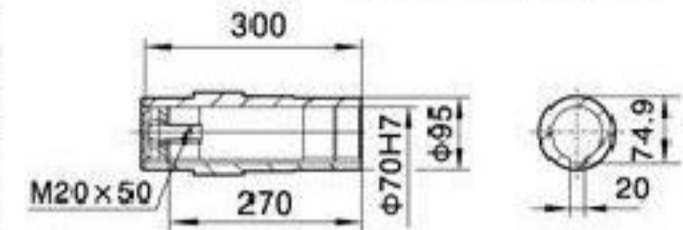

F..T97

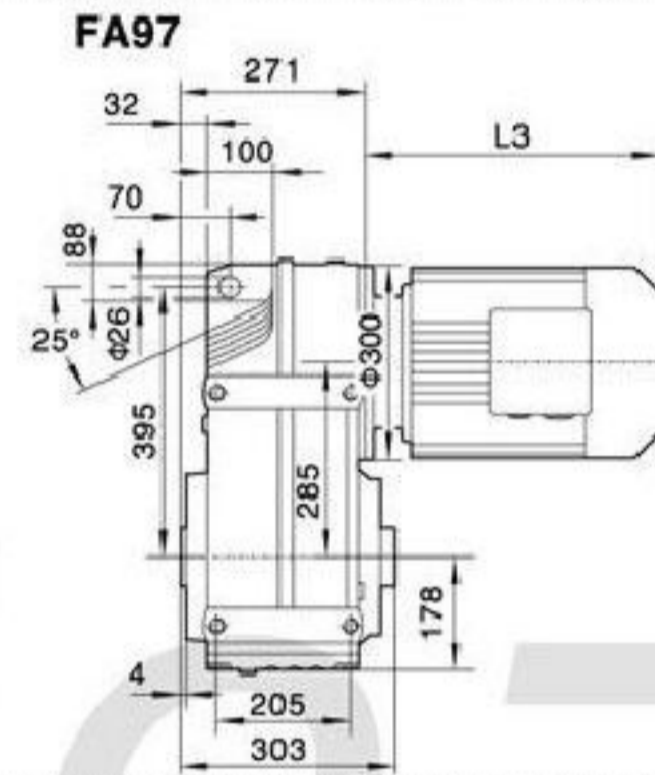

FAZ97

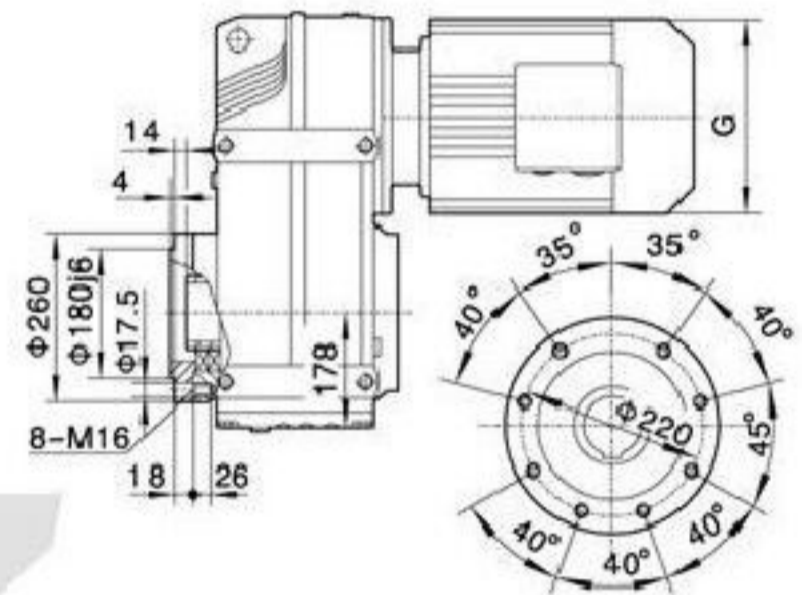

F

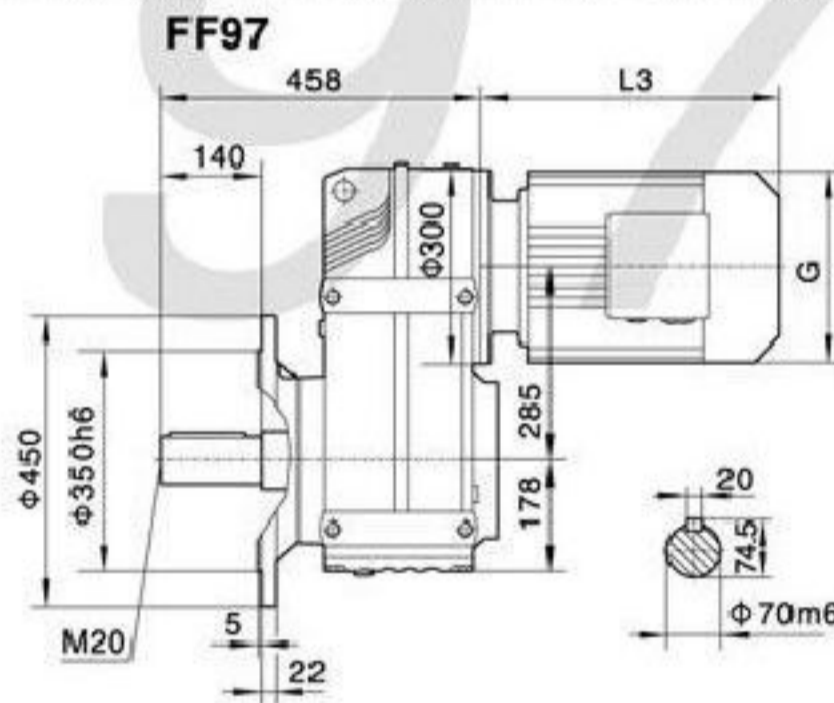
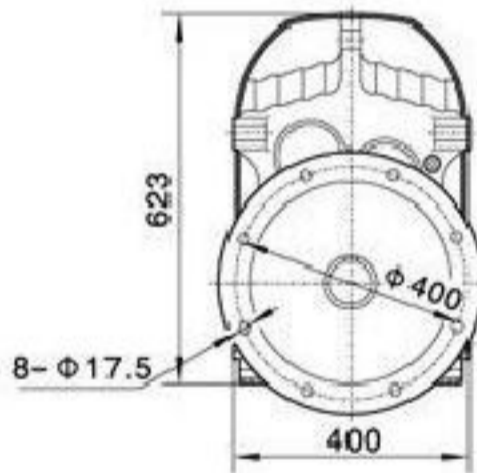

FAF97

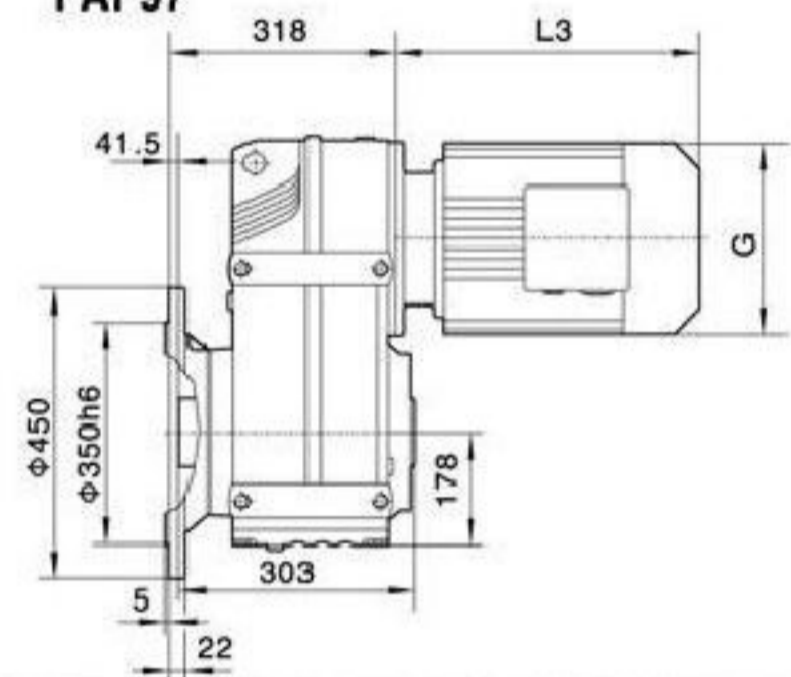

电机需方配或配特殊电机时需加联接法兰

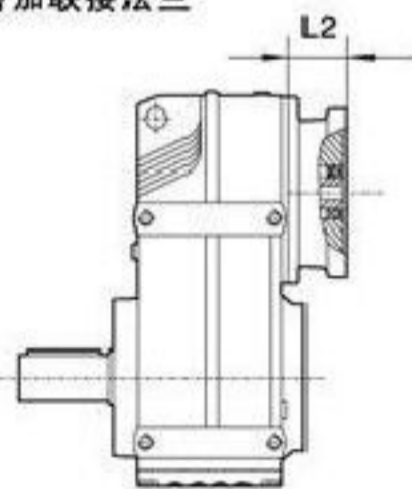

F..S97

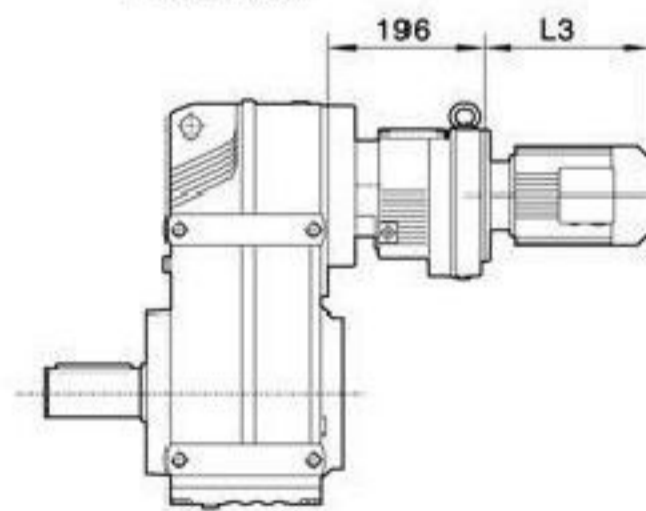

F..S97

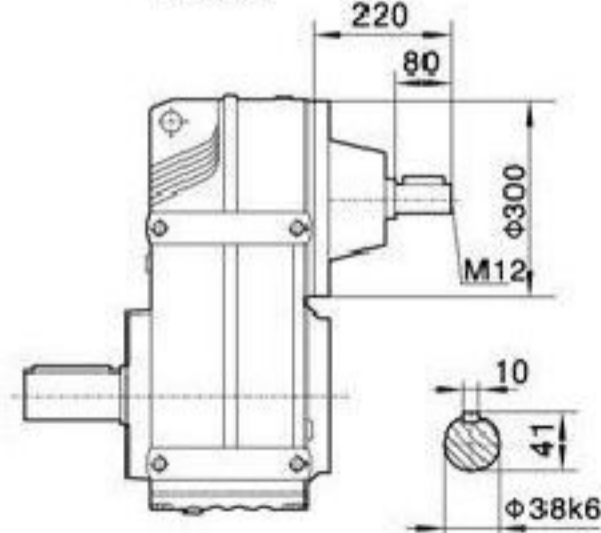

注：其余尺寸见相对应结构形式

Note: For other values please refer to the opposite structure.

When equipping the user's motor or the special one, the flange is required to connected.

Y2电机机座号 Motor size 功率/4P Power/(kW)	90S	90L	100	112M	132S	132M	160M	160L	180M	180L	200
L3	280	304	315	334	425	461	524	547	555	588	654
G	195	195	215	240	275	275	330	330	380	380	420
L2	86	86	101	101	101	101	126	126	126	126	132

注:1.以上壳体为通用件,安装尺寸均可相互参照 2."F.."表示F、FA、FF、FAF、FAZ

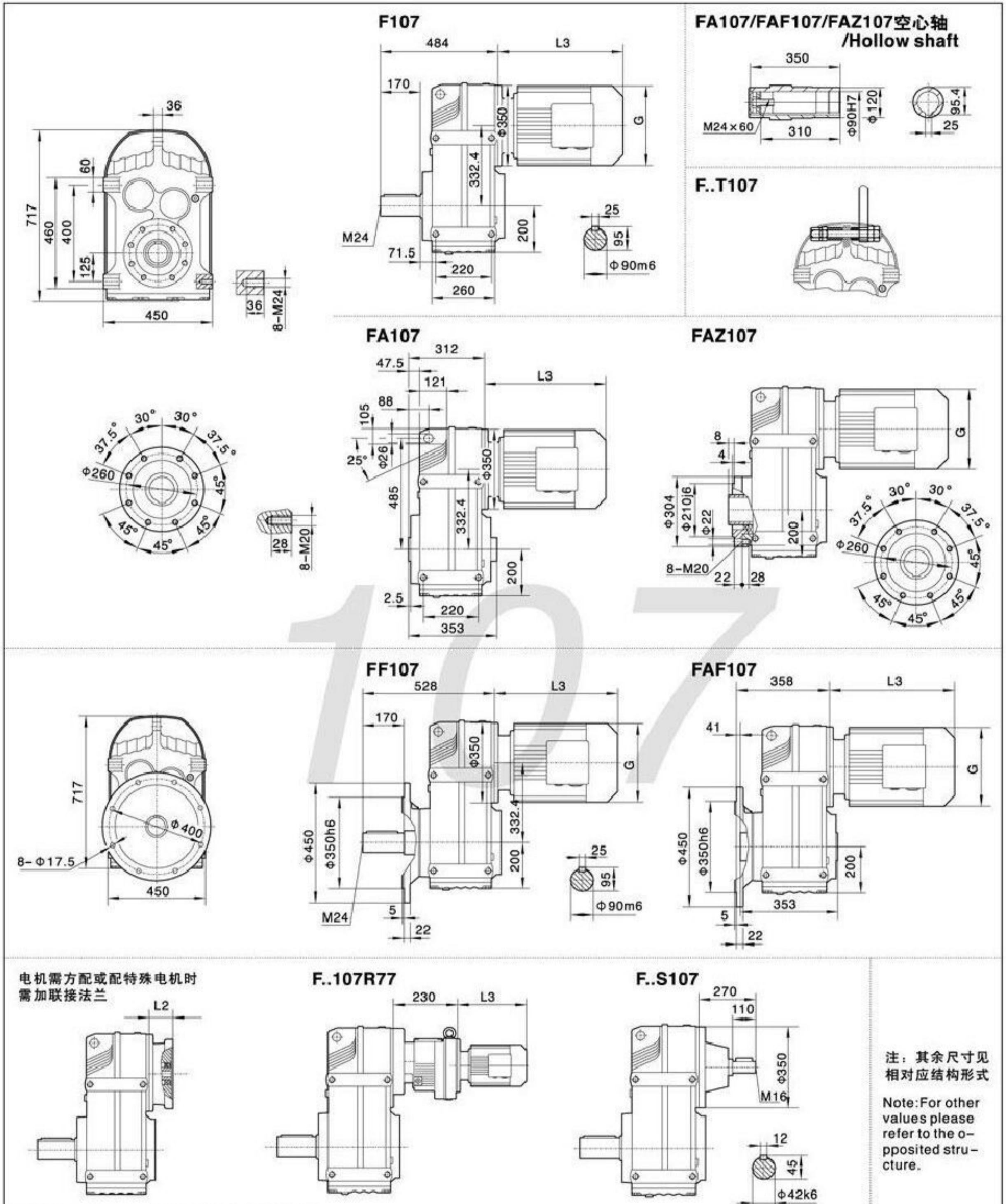

注：其余尺寸见
相对应结构形式
Note: For other
values please
refer to the o-
pposited stru-
cture.

电机需方配或配特殊电机时
需加联接法兰

When equipping the user's motor or the special
one, the flange is required to connected.

Y ₂ 电机机座号 Motor size	100	112M	132S	132M	160M	160L	180M	180L	200	225S	225M
功率/4P Power/(kW)	2.2 3	4	5.5	7.5	11	15	18.5	22	30	37	45
L3	318	334	386	422	504	519	555	588	654	680	702
G	215	240	275	275	330	330	380	380	420	470	470
L2	101	101	101	101	126	126	126	126	132	132	132

注:1.以上壳体为通用件,安装尺寸均可相互参照 2."F.."表示F, FA, FF, FAF, FAZ

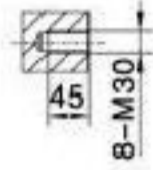
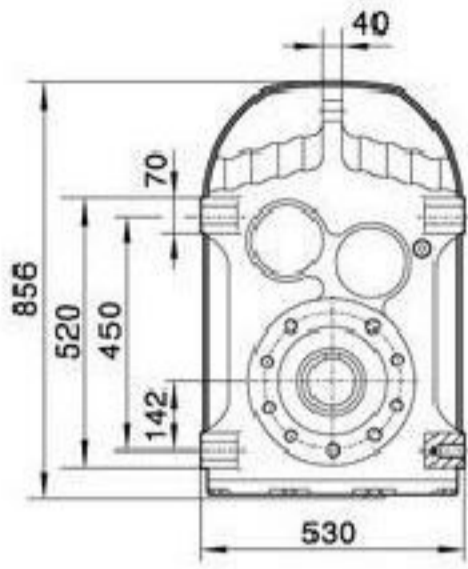

F127

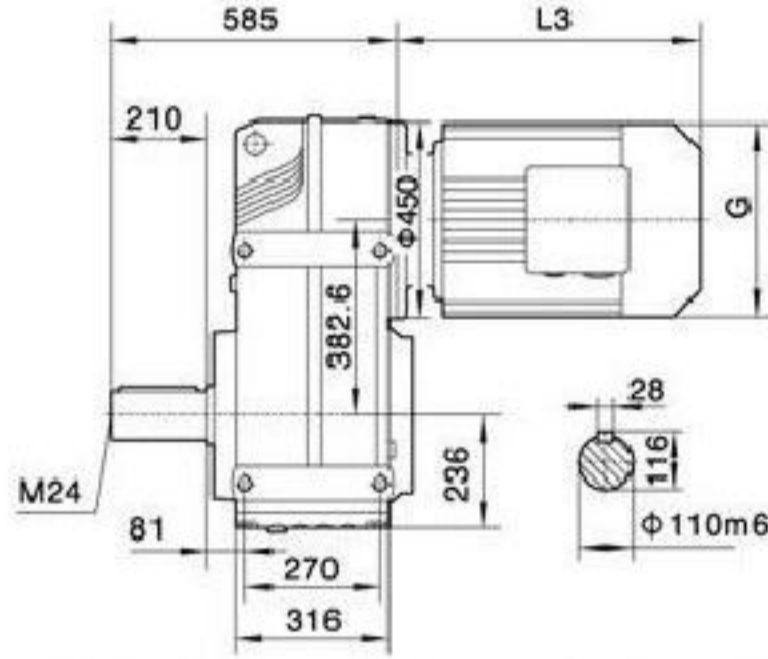

FA127/FAF127/FAZ127空心轴 /Hollow shaft

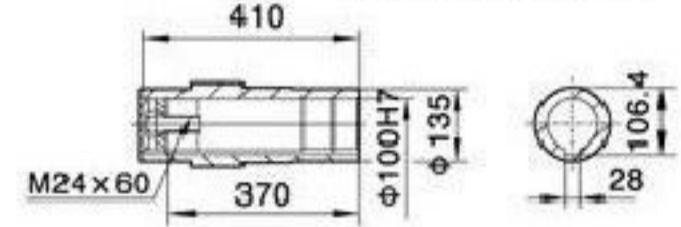

F..T127

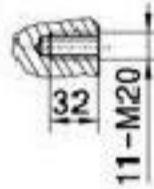
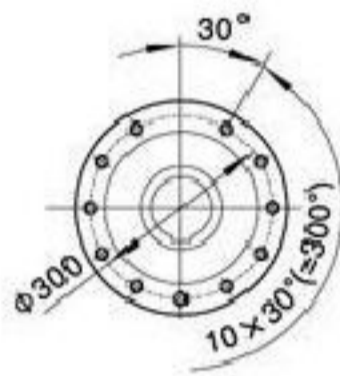

FA127

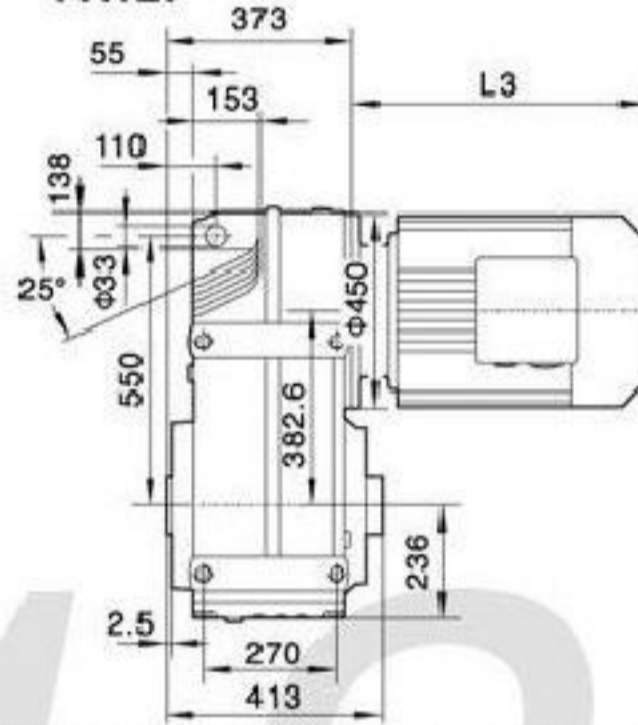

FAZ127

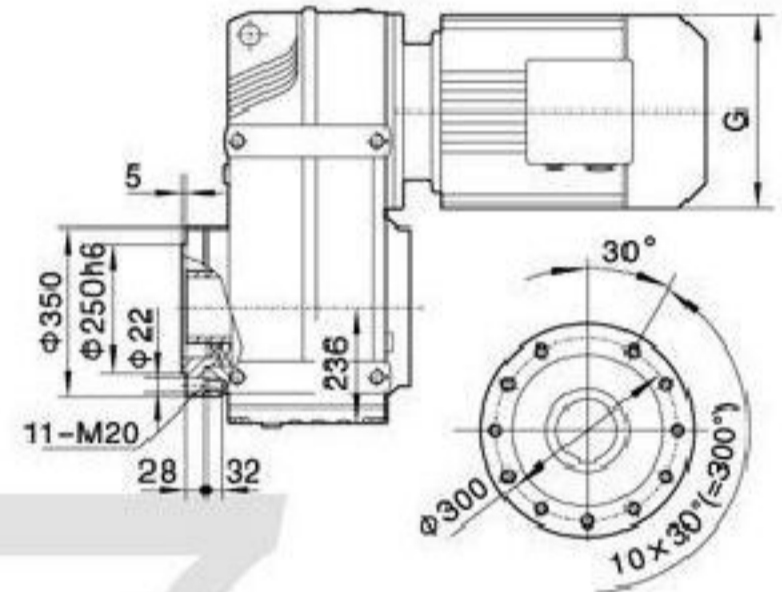

F

FF127

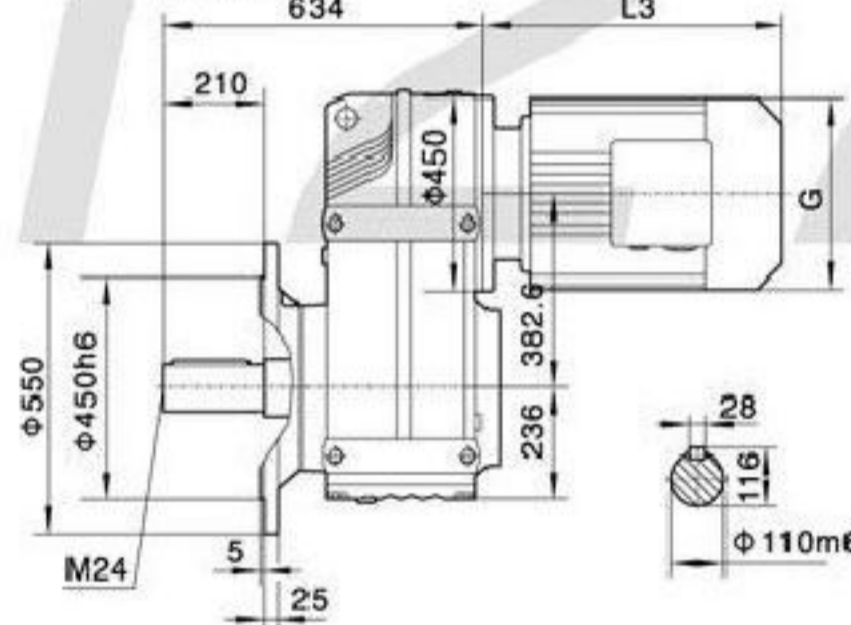
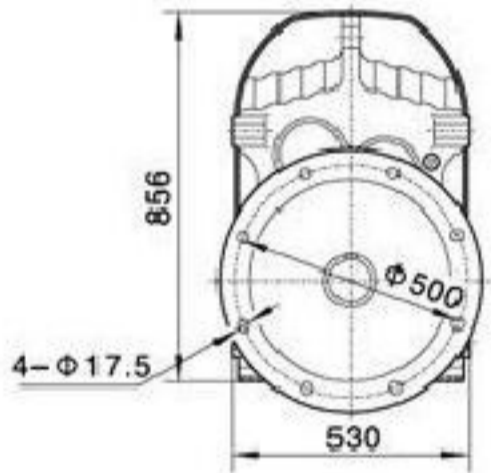

FAF127

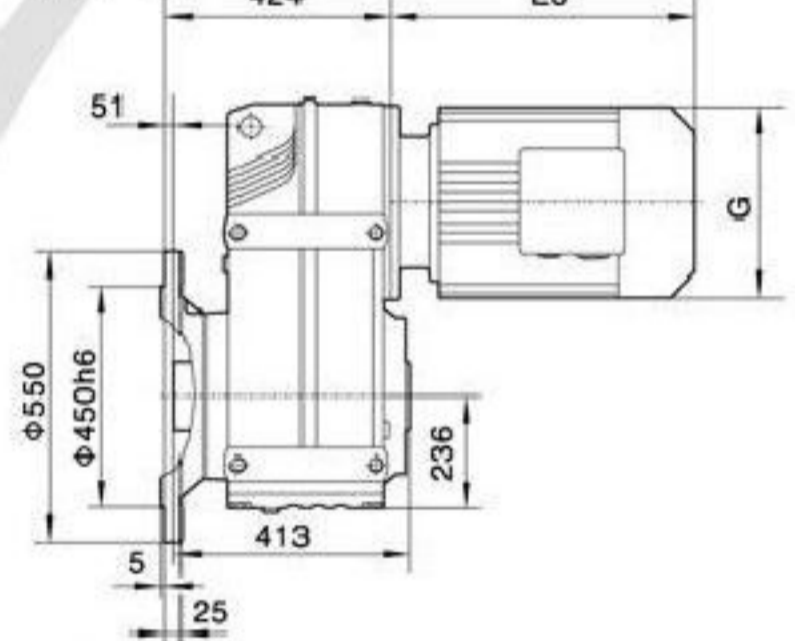

电机需方配或配特殊电机时
需加联接法兰

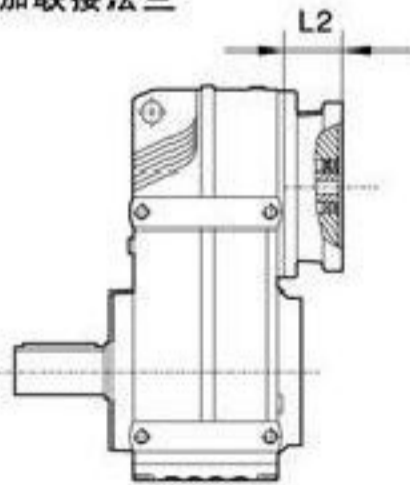

F..127R77(R87)

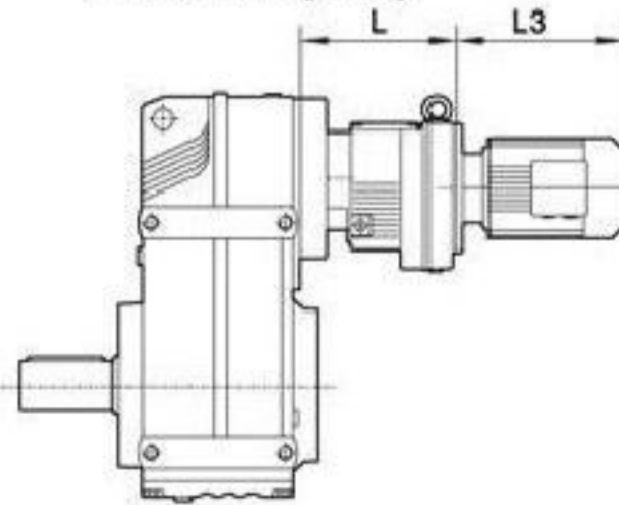

F..S127

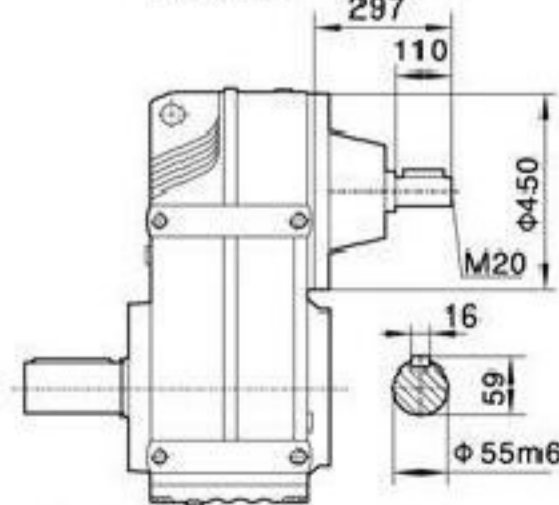

注: 其余尺寸见
相对应结构形式

Note: For other
values please
refer to the o-
pposited stru-
cture.

When equipping the user's motor or the special one, the flange is required to connected.

Y2电机机座号 Motor size 功率/4P Power/(kW)	132M	160M	160L	180M	180L	200	F..127R77		F..127R87		280S	280M
							L	230	275			
L3	424	567	602	583	616	654	674	696	775	847	847	
G	275	330	330	380	380	420	470	470	510	580	580	
L2	132	132	132	132	132	132	143	143	174	174	174	

注: 1. 以上壳体为通用件, 安装尺寸均可相互参照 2. "F.."表示F, FA, FF, FAF, FAZ



重泰减速机

ZHONG TAI REDUCER

品质铸就品牌

F157

FA157/FAF157/FAZ157空心轴 /Hollow shaft

F..T157

FA157

FAZ157

FF157

FAF157

F..157R97

F..S157

电机需方配或配特殊电机时需加联接法兰

When equipping the user's motor or the special one, the flange is required to connected.

注: 其余尺寸见相对应结构形式
Note: For other values please refer to the opposite structure.

Y ₂ 电机机座号 Motor size 功率/4P Power/(kW)	160M	160L	180M	180L	200	225S	225M	250	280S	280M	315S	315M	315L
L3	567	602	635	666	642	669	691	770	828	879	1100	1180	1270
G	330	330	380	380	420	470	470	510	580	580	645	645	645
L2	143	143	143	143	143	143	143	143	143	143	145	145	145

注: 1. 以上壳体为通用件, 安装尺寸均可相互参照 2. "F.."表示F, FA, FF, FAF, FAZ

F